

Chapter Three

# THE STAFF OF LIFE,

G.J. Hollamby

The History of Plant Breeding at  
Roseworthy Agricultural College

Reprinted from

**ROSEWORTHY AGRICULTURAL COLLEGE  
-A CENTURY OF SERVICE**

edited by Jeff Daniels (1983)

ROSEWORTHY AGRICULTURAL COLLEGE

Roseworthy, South Australia, 5371.

GRIFFIN PRESS

## CHAPTER 3

# *The Staff of Life*

G. J. Hollamby

The improvement by selection or hybridisation of those plants upon which man is dependent for his subsistence affords unlimited scope for the highest talent. With the aid of science, man in a few years may accomplish as much in this direction as natural selection in the course of centuries, and anyone who devotes his serious attention to this most fascinating pursuit may well be regarded as a benefactor to his fellow creatures.

A. B. Robin, Nuriootpa (Foundation student of Roseworthy Agricultural College)

### *In The Beginning*

Roseworthy College has been involved with wheat improvement since its inception. Professor Custance established trials of various agricultural plants in 1882 including 27 different wheat varieties.<sup>1</sup> In 1883 he tested 35.<sup>2</sup> These included recognised South Australian varieties and importations from England, India, South Africa and New Zealand. He was convinced that early maturity and drought tolerance was necessary for local conditions which were drier than found in most other wheat growing countries. However, it was not until 1904 that the first plant breeder, W. J. Spafford, was appointed to the College staff. During these intervening years the College was often castigated by farmers for not doing more in wheat variety improvement.

South Australia was the granary of Australia during the period 1860–1890,<sup>3</sup> and because of the close proximity of the wheat growing areas to the coast, there developed a significant export trade to the United Kingdom. The dry summers of South Australia's mediterranean climate meant that the wheat was less subject to diseases especially red rust which so frequently caused damage on the east coast of New South Wales. Not surprisingly, astute farmers in South Australia made considerable improvements in the wheat varieties grown in the colony. Mr J. Frame, a farmer at Mt Barker, selected Purple Straw in about 1860. This variety, the most popular wheat in the 1860–90 period, was earlier maturing than other wheats of the time and suffered less from the rust epidemics of 1867. It is one of the most important ancestors of our present varieties. Other important farmer selections included Ward's Prolific (Port Pirie), Steinwedel (Balaklava) and Early Gluyas (Port Germein).<sup>4</sup> Each was named after the farmer who selected and propagated them. Richard Marshall, of Hope Farm, Wasleys, was the most zealous of these farmers and not only selected from heterogeneous varieties but carried out purposeful crosses to create new genetic combinations from which to select better types for improved adaptation, early maturity, strong straw, rust resistance and better milling qualities. Marshall produced very important varieties, for example, Marshall's No. 3 and Yandilla King. Marshall's No. 3 replaced Purple Straw as the most widely grown variety until the variety Federation. His incentive in this work came from having lost his crops to rust in 1867 and 1891, from corresponding with and being visited by William Farrer, Australia's most famous wheat breeder, and from a keen desire to improve agriculture in South Australia. Marshall became very disenchanted with those in authority in South Australia because they gave him no encouragement, and often opposition, for work which he felt they themselves should be carrying out. In 1893 he and Professor Lowrie clashed at an agricultural bureau meeting about the value of artificially crossing wheats to combine rust resistance with other desirable characters.<sup>5</sup> Many times after that Marshall

castigated Lowrie for not taking account of the milling qualities of wheat and, in fact, helping to boom the popularity of good yielding but inferior quality wheats<sup>6, 7, 8</sup> e.g. King's Early. Marshall had in 1897 urged the Minister of Agriculture to procure and erect a test mill for testing wheat variety qualities before their release to farmers, believing that increases in milling qualities could lead to a premium price of 6d above the current prices, or £600,000 extra income annually to South Australia.<sup>8</sup> This mill was procured and sent to Roseworthy where it still lay in pieces 5 years later.<sup>9</sup> Professor Lowrie explained that he had been keeping up with the eminent work of the breeder-chemist combination of Farrer and Guthrie in New South Wales and did not see a need for it to be repeated at Roseworthy.<sup>7</sup>

For several years, 1894–6, M. McBain, under Lowrie's supervision, had introduced to Roseworthy crossbred wheats from William Farrer in order to select for Stem Rust resistance and for fixing the type. Lowrie complimented Farrer for 'taking such infinite trouble in the growing and crossbreeding of varieties of wheat and [distributing] them to the different colonies to be fixed so freely'. Other collaborative experiments with Farrer were conducted in 1902 and 1903 to seek bunt resistant wheats.<sup>10</sup> This work with wheat varieties tended to wax and wane and apparently was never a serious part of Lowrie's activities.

At the College during this time was Arthur J. Perkins, Government Viticulturist. He no doubt was observing this situation with interest and on becoming Principal of the College in 1904 was in a position to change it. He impressed farmers on their first visit after his appointment as Principal. It was reported that 'a more vigorous policy of experimental research is expected. . . . The tour of the paddocks on Monday suggested that the time has arrived when a greater variety of wheats should be tested and that the schedule of experiments should be more comprehensive'.<sup>11</sup> Indeed he retained this conviction throughout his Principalship.<sup>12</sup> He appointed a recent College graduate, Walter J. Spafford, as Assistant Experimentalist in 1904. This response to farmer pressure was probably too long in coming because the Director of Agriculture, Prof. W. Angus, established a wheat breeding programme at the newly acquired Parafield Experiment Farm in 1907 to which A. E. V. Richardson was appointed in 1908. Richardson was to continue his work in Victoria and finally set up wheat breeding at the Waite Agricultural Research Institute in 1925. Thus there were, and still are, for better or worse, two separate wheat breeding programmes in South Australia. The Parafield programme was transferred to Turretfield in 1913 but gradually changed its objectives to become a wheat seed farm.

### *Daphne—Roseworthy's First Crossbred Wheat*

Together, Spafford and Perkins did much at Roseworthy and released a number of wheat varieties by plant selection from heterogeneous varieties being grown by farmers. In fact just after becoming Principal, Perkins was deeply struck with the extent of the variation and running down of King's Early (selection from Early Baart by J. King, Georgetown) so he commenced reselection eventually to have a much improved strain for farmers in 1911.<sup>13</sup> To a large extent this single plant selection was based on taking large headed plants from crops. Selection of this nature led also to Bearded Gluyas, Late Gluyas, King's White and King's Red. Unfortunately they showed a reluctance to accept the role of crossing in wheat improvement and in a paper as late as 1908, 10 years after Farrer's famous paper<sup>14</sup> on hybridisation and 7 years after the rediscovery of Mendel's works, they wrote:

Personally, as a factor in the creation of new varieties, we attach far greater importance to selection than we do to crossbreeding. . . . At best cross-breeding is only a haphazard way of getting out of a difficulty, it breaks down the fixity of the type to which we are accustomed, and the new plants sport in all directions. . . . its pseudo-scientific ring [has] not succeeded in firing our somewhat sober imaginations.<sup>15</sup>

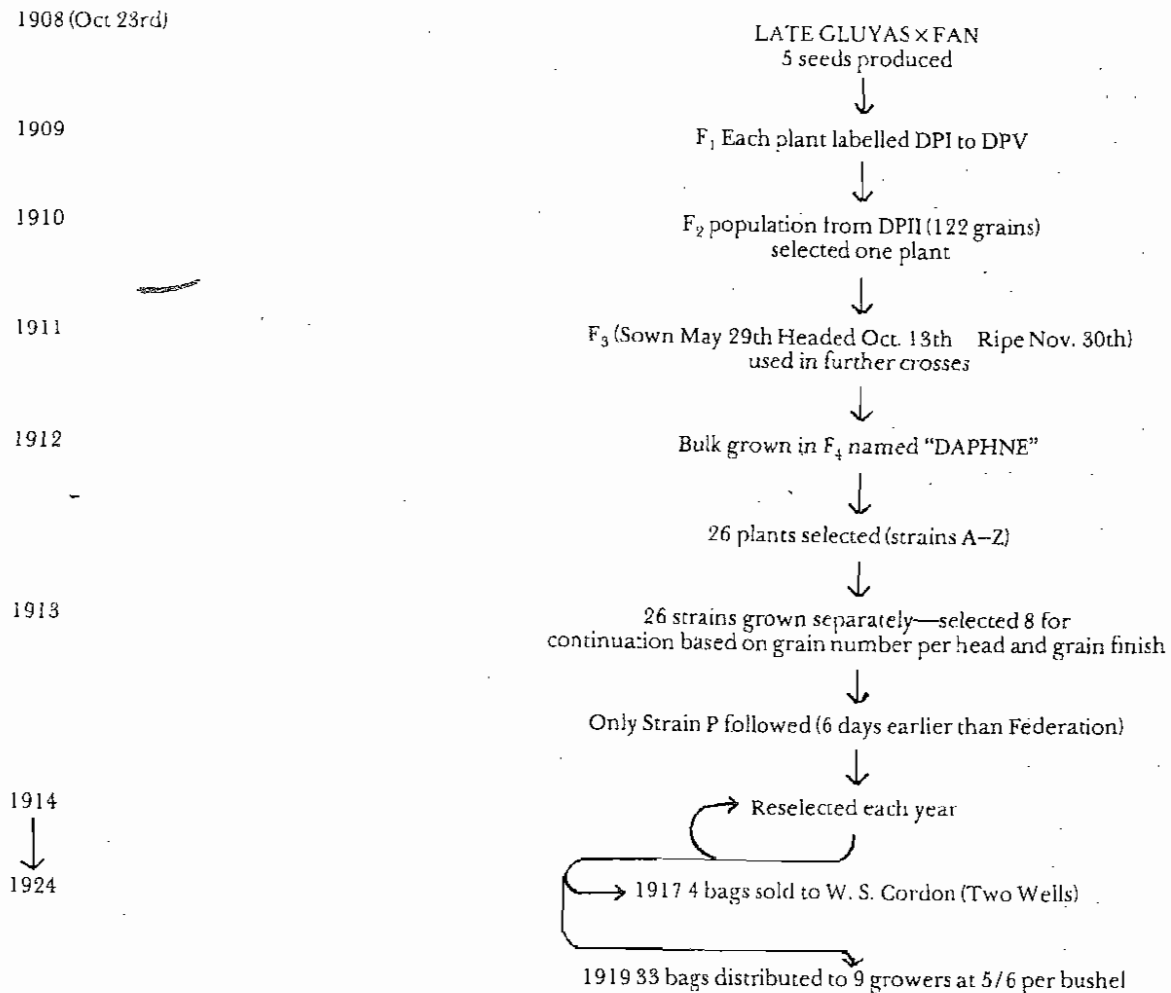

Figure 1: Selection history of DAPHNE

They continue: 'Nevertheless, to satisfy the public, we determined to come into line and see what could be done with crossbred wheats'.

Spafford made 22 crosses in 1906, the first one being entered in his field book on November 17th, *Bearded Rieti* × *Petanielle Blanche*. Two F<sub>1</sub>\* grains only were produced and in the next season one of the resultant plants was eaten off by hares just after emergence. In that first bout of crosses at Roseworthy some showed up as 'grass clumps' (extreme dwarfism and non heading character now known to be controlled by 2 dominant complimentary genes), a problem which still plagues breeders today and often prevents carefully planned crosses from being successful.

Fifty-five crosses were made in 1907 with a further 60 in 1908, and it was not long before Spafford saw in the results of these crosses useful new varieties and realised that crossbreeding or hybridisation gave the opportunity for simultaneous recombination of desirable characters from more than two varieties within a population even though there was a long selection period required to obtain true breeding types. Top crosses, e.g. (*Bearded Rieti* × *Gluyas*) × *Jonathan*, and backcrosses, e.g. (*Marshall's 3A* × *Indian Runner*) × *Marshall's 3A* have been a feature of the crossing programme since 1909. These two crosses led to the varieties *Echo* and *Earl* respectively, but they were never widely grown and the reasons for the crosses or their selection can only be guessed at.

Two varieties originating from these early crosses and destined to be widely grown were *Daphne* and *Caliph*. *Daphne* was grown in South Australia for over 20 years and in 1926 was the 6th leading variety in the State, being planted on 51,892 ha, or 4.2% of the

\*F stands for filial, a symbol used by breeders to indicate the number of generations after the original cross was made between two parent varieties. Therefore, F<sub>1</sub> is the first generation, F<sub>2</sub> the second and so on.

wheatlands.<sup>16</sup> It was also grown in Western Australia. Caliph reached 63,000 ha in 1927. The breeding and selection of Daphne, shown in Figure 1, is typical of Spafford's programme. It is interesting to note that varieties were usually named and sometimes released only four years after hybridisation, and many were named and released in the same year, as shown in Figure 2. These varieties would not have been fully fixed and certainly not fully tested and it is probably for this reason that so many were never widely grown.

Professor Perkins left the College to become Director of Agriculture in 1914. Spafford followed him as his right hand man, as Superintendent of Experimental Work. Thus he was still able to maintain his contact and interest in wheat improvement. He published frequently in the *Journal of Agriculture* and exhorted farmers to prevent their wheats from deteriorating or even to improve them, by careful plant selection. By 1915, from his own experience, he did acknowledge the value of cross-breeding but said that because it needed an enormous input of time and money, it was really the lot of the experts in institutions.<sup>17</sup> He published a very comprehensive paper, 'The Cross Fertilisation of Wheats',<sup>18</sup> in an effort to show that this form of breeding was not really within the capacity of the ordinary farmer. In the paper he described in minute detail the emasculation and pollination process, the recording of crosses and data, and the growing and harvesting of the next three generations.

Like many other enthusiastic College staff he was missed by the whole College community for reasons outside his wheat expertise. He evidently was a leader rather than a boss and was very popular with the student work gangs both outside and inside the laboratory. His sound knowledge and enthusiasm were very catching and 'his peculiar gesticulations when explaining anything or directing one, were very arresting and so original that one could not forget them in a lifetime'.<sup>19</sup>

### *Ford*

The work of the Experimentalist cum demonstrator in Agriculture cum lecturer in Agriculture had become so important that the vacancy left by Spafford was soon filled by Robert C. Scott. He had graduated from Roseworthy College with honours and spent one year farming at Booborowie before taking up his position in July 1914. He inherited Spafford's material and no doubt had, from his student days, a fair knowledge of the plant breeding system. Thus he was able to go straight to work. In 1916 he finished selection of and named Ford, a variety derived from a complex cross [(Fan × Comeback) × (Zealand × Tardent's Blue)] made earlier by Spafford in 1911. This variety is one of the three most important wheats produced from Roseworthy. It was being grown to a small extent as late as 1965, nearly 50 years after its release. However its heyday was in the 1930s. It was the third leading wheat in Australia in 1935, sown on 408,000 ha or 8% of the wheatlands. There were still 148,000 ha planted in 1948.<sup>16</sup> Ford was grown more extensively in New South Wales than in South Australia because the longer, more favourable growing season in that State was more appropriate to its maturity. At the time it offered resistance to Flag Smut and Stem Rust and because of its medium-strong flour quality did much to improve the general marketability of the wheat harvest. The popularity of Ford in New South Wales and its lesser popularity in South Australia has caused many farmers mistakenly to believe that it was a New South Wales bred variety.

### *Sword*

Other important wheats from the joint work of Spafford and Scott were Felix and Sultan. Scott's first solo variety was named Scotts No. 1 (Federation × College Eclipse) but this was never grown commercially as is usual with most breeders' early efforts.

Varieties derived from crosses made in the late 1910s and early 1920s were named by constructing new words out of syllables and letters from the parents. Gluford was

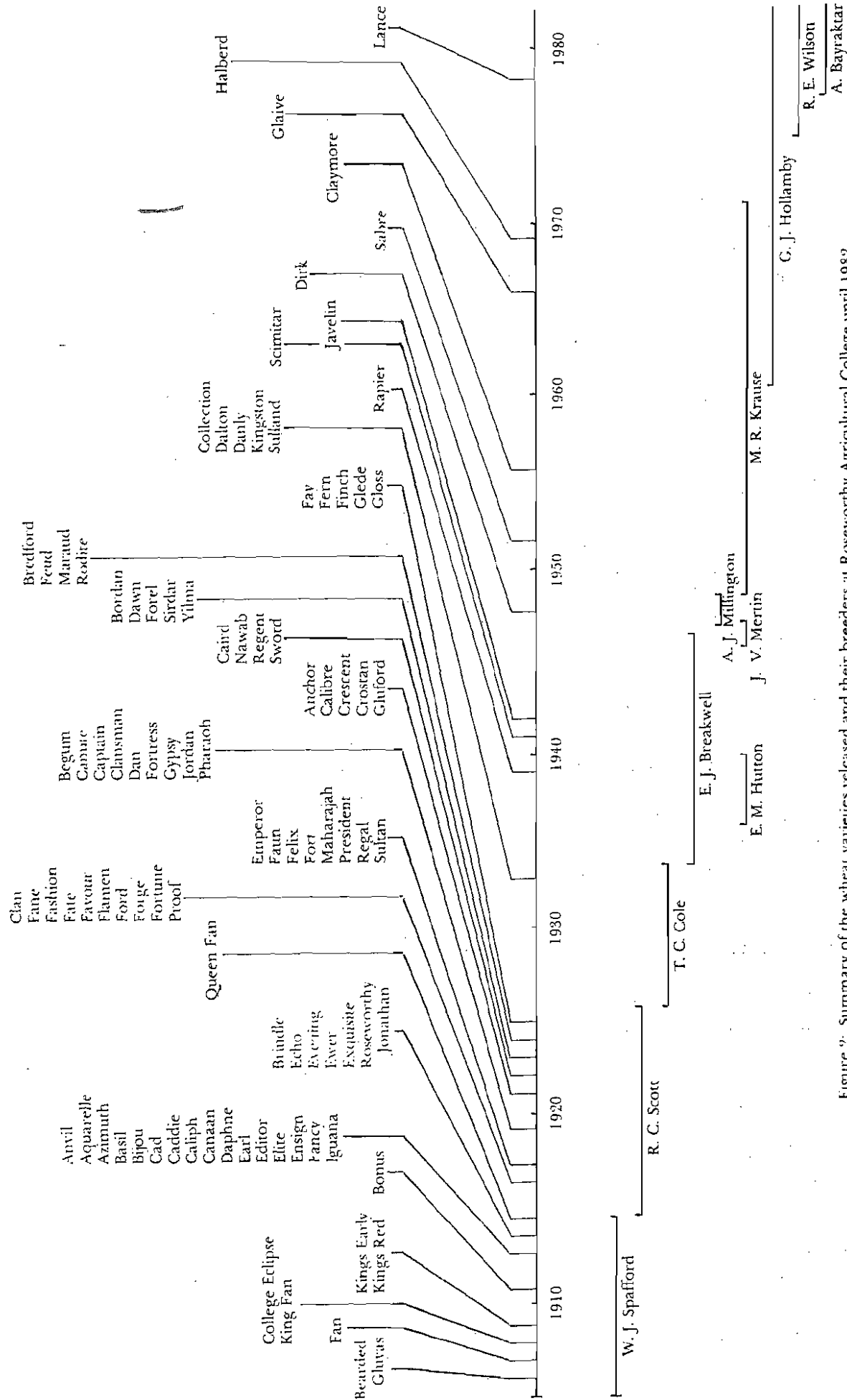

Figure 2: Summary of the wheat varieties released and their breeders at Roseworthy Agricultural College until 1982.

Accepted for publication 1982. This paper is published in the Journal of the Australian Wheat Board, Volume 11, Number 1, 1982, pages 40-41.

selected from the cross Gluyas × Ford, Caird from Caliph × Ford. Most significant of this era was the cross Sultan × Ford from which was selected the second of Roseworthy's top wheats, Sword. Earlier maturing than Ford, it was very readily accepted in South Australia as a prolific variety for mallee areas. At its release, it had some resistance to Stem Rust, and in 1936 it was sown to 11.2%, or 158,200 ha, of South Australia's wheatlands. Its selection history is shown in Figure 3.

The breeding method of Scott is not different to that of Spafford as comparisons between the Daphne and Sword charts show. They both used strict Pedigree Methods, with single plant selections being carried out each year that a line remained under test or in seed multiplication. This type of selection procedure is very time consuming and labour intensive. It has not been possible to determine total numbers of lines or plots under test each year during Scott's time but approximately 60 crosses were made annually. During this time harvesting would have been carried out by horse-drawn implements, or by hand, binding the experimental plots into sheaves for thrashing in a stationary thrasher. A student reports in his diary in February 1916:

By Xmas Eve practically all the experimental plots had been threshed. Work lapsed from 4 pm Dec. 24th to 1 pm Dec. 27. . . . Occasional delays were experienced due to an ineffective blower which continually blocked up and also to the breaking of certain castings connected with the cocky chaff shakers.<sup>20</sup>

The straw as well as the grain was valuable in those horse power days, so that some wheats were considered and tested for hay as well as grain production. Scott was very interested in Nizam\*, and Sirdar, a solid strawed variety Felix × Tunis.<sup>21</sup> We may complain about conversion to metrics today, but imagine the complexity involved in the expression of the average hay yield per acre of Sirdar in the period 1927–30, recorded as 1t 13c 106l, with a grain yield of 17b 37l.<sup>22</sup>

Scott was responsible for running other experiments as well as wheat breeding. He conducted a fat lamb breeding programme with W. J. Colebatch, the Principal. He also managed the farm. He did however have some help during this time from F. Riggs (pre 1919) and V. M. Fairbrother (during the 1920s) who were assistant experimentalists for a time.

Sword is an interesting variety not only for its past performance but because it is still grown as a hay wheat in a few areas. Most of the older generation of farmers will have seen it growing. Its fame and name led eventually to the weapon series of names, of which more anon.

During this time South Australian wheats found their way to North Africa and the Roseworthy varieties Rajah, Fan, Iguana and Bearded Gluyas were doing well in Morocco.<sup>23</sup>

Scott followed Spafford into the Department of Agriculture in late 1927 as Supervisor of Experimental Work and whilst there established himself as 'one of the most sound agriculturalists in Australia'. Spafford became Director and Scott his Chief Agricultural Adviser.<sup>24</sup>

## Cole

Tom A. Cole succeeded Scott in 1927. He was a graduate from Dookie Agricultural College, and quickly endeared himself to the College and district communities by taking a keen interest in Scouting and Guiding, cricket, football and tennis. He also captained the College rifle team. No new varieties were released by Cole but several important events in the continuing improvement of the wheat breeding programme took place. A cross was made between Nabawa (then the most popular wheat in South Australia) and

\*Around the time of the release of Nizam (1919) many Roseworthy wheats were given the names of Eastern rulers (Maharajah, Caliph, etc.). Nizam is a Muslim Prince of India. However Victoria also released a wheat named Nizam so Roseworthy renamed its variety as Begum in 1928, after a Muslim Princess of India.

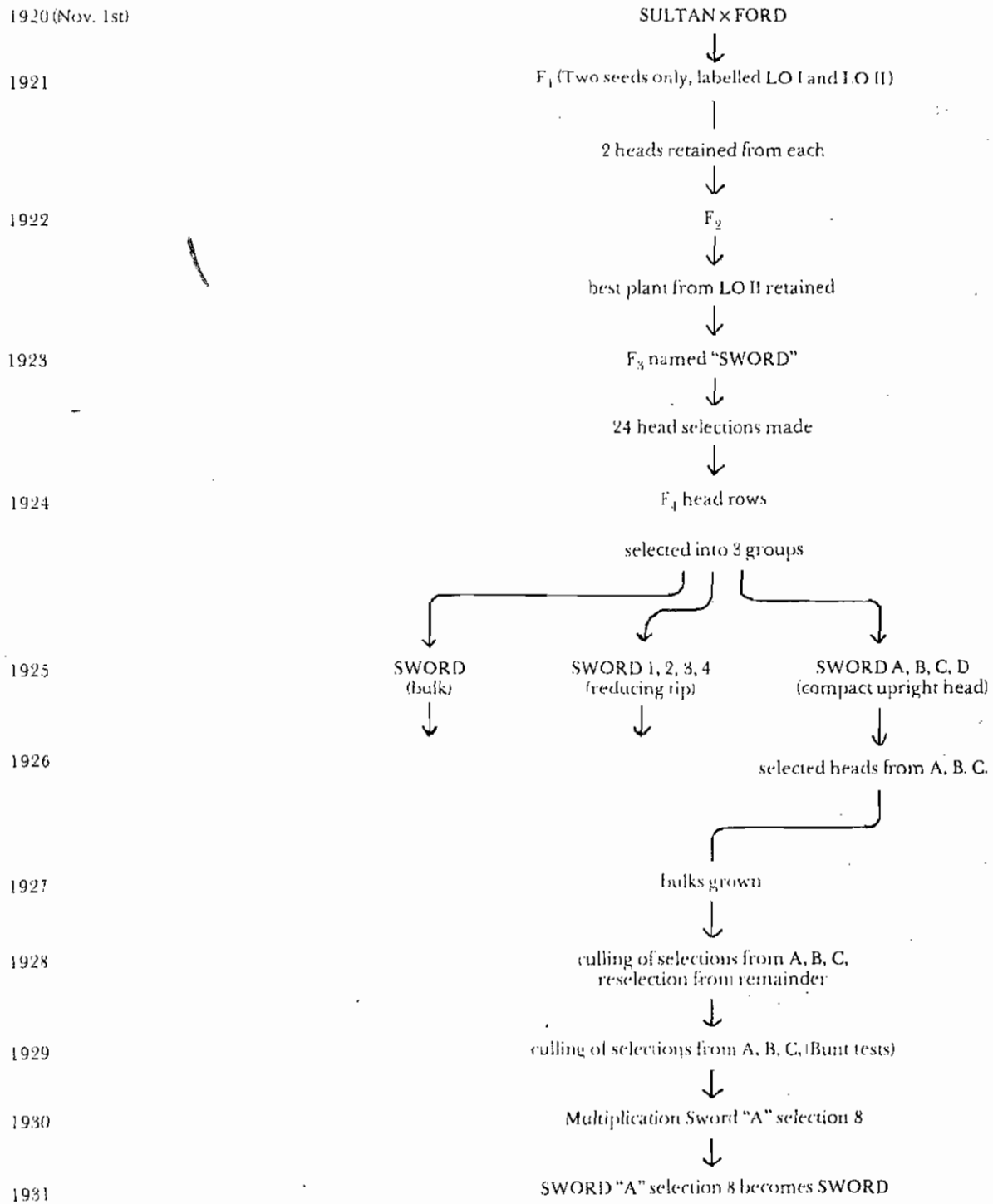

Figure 3: Selection history of SWORD



Egyptian 4 probably to improve the inherently weak flour of Nabawa. From this cross was later derived Scimitar.

Mechanisation also commenced as reported in the College magazine, *The Student*, of December 1932:

With the help of the new motor stripper now being constructed in the mechanic's shop the harvesting of stud rows can be much more efficiently performed.<sup>25</sup>

At that time the stripper was horse drawn, although many students since will well remember this machine with its one cylinder Ronaldson-Tippett petrol-driven engine and large cooling water reservoir located just behind the driver, whose legs were splashed every now and then by boiling water from it. More recent students may best remember it without its front wheel, towed by a Ferguson tractor, or, in the case of still more recent students, with the motor removed and the beaters driven by a hydraulic motor from a pump mounted just above the PTO shaft on an MF35 tractor.

The most endearing memory, however, will surely be that of lifting the beater cover at the end of each plot to allow a draught to blow chaff out of the grain box, the contents of which had to be stirred with a rake until clean, whereupon one reached in and swept the grain into a sugar bag with a bannister broom. Sometimes too, it would be used as a stationary thrasher with a piece of galvanised iron bolted over the comb so that sheaves could be pushed into it. It still exists as a back-up machine although it has not been used for two years.

Another important step during this period was the use of biometrics in analysing crossbred yield data. The 1929 and 1930 trial yields were assessed using the Standard Error of the difference between pairwise comparisons of selections. Nine replications were used but it is not certain whether these were randomised. The Standard Errors were about 5% of the mean, so trials were well performed on even sites. Cole evidently used the 1927 work, *Breeding Crop Plants*, by Hayes and Garber, as his text.<sup>26</sup>

The important statistical methods based on randomisation and replication had been proposed by R. A. Fisher at Rothamstead, UK in 1925.<sup>27</sup> Roseworthy was thus quick to adopt these techniques.

### *The First Plant Breeder Appointed*

Cole left the College in 1933 to take up farming in Victoria, soon after Allan R. Callaghan was appointed Principal. Callaghan became Principal in 1932 after a distinguished scholastic career culminating with a doctorate of philosophy whilst a Rhodes scholar at Oxford. His thesis on the oat plant and his subsequent work at Cowra and Wagga Experiment Farms in New South Wales gave him a deep understanding of plant breeding and related topics. He did make some crosses with oats whilst at Wagga.

This background gave Callaghan some very definite ideas on research needs and the requirements of the Australian cereal industries and he forcefully set about putting these ideas into practice. Under Callaghan's direction, plant breeding at Roseworthy entered a new era, an era which allowed it to progress from a part-time to a full activity of the College.

As early as 1933 he outlined the work in progress and what developments were envisaged.<sup>28</sup> He was concerned about the poor quality of South Australia's FAQ\* wheat which had been brought about by widespread production of high yielding but weak floured varieties such as Nabawa (from New South Wales) and Free Gallipoli (from Victoria), and vowed Roseworthy would correct this situation by seeking varieties which combined high yield, disease resistance and good quality as well as strong straw and non-shattering characteristics. This task, he pointed out, would be slow but the expenditure would be well worth it.

\*FAQ stands for Fair Average Quality, a classification no longer in use, by which the standard of wheat produced was measured. The expression is occasionally used in everyday speech to describe something as satisfactory.

He appointed E. J. (Jim) Breakwell in 1933 as Plant Breeder and together the two of them made a lasting impression on Australia's wheat crops. Breakwell's appointment was very significant. Firstly, he was the first full time Plant Breeder, those before him being Experimentalists with many other tasks besides plant breeding. Secondly, he was the first in the breeding team to have been trained and to have experience in plant breeding. Breakwell was a graduate of Sydney University where he studied under Professor W. L. Waterhouse, a wheat breeder whose varieties included Gabo and who was then Australia's authority on wheat Stem Rust. Breakwell had also been assistant plant breeder at Glen Innes Experiment Station. Thirdly, he had had no previous association with the College wheat breeding programme so had no preconceived or traditional ideas to maintain.

Breakwell, then, had the necessary training, the time and the encouragement of his Principal, and was thus able to develop a large and successful programme. These factors, coupled with his enthusiasm—which rubbed off onto his fellow workers and students—led to a number of very important varieties being released, with other lines, whilst not warranting release, having some very desirable characteristics which made them valuable parents for continued upgrading of the breeding material. His student contact with Waterhouse set him in good stead too to exchange breeding lines with New South Wales programmes.

His first improvement was to put Pure Seed Production of current varieties onto a more scientific basis in order to keep South Australia's crops more true to type (as illustrated in Figure 4). This method is not very much different from that in use today.

From 1933 wheat variety evaluation trials have been laid out as Complete Randomised Block designs,<sup>29</sup> interestingly, 15 years before these same scientific techniques of comparing varieties and taking account of uncontrolled background and experimental error were used by the Department of Agriculture.

Another example of Callaghan's and Breakwell's enthusiasm and scientific readiness was the speed with which they adopted the new Wholemeal Fermentation Test in order more efficiently to achieve their quality objectives. This test was developed by Pelshenke in Germany in 1930 as a means by which both the quantity and quality of wheat protein could be estimated from a small amount of grain. It was in use at Roseworthy in 1934.<sup>30</sup> Thus the breeders had a test which although not able to show differences between good and reasonable quality wheats (as was pointed out by chemists at the Department of Chemistry<sup>31</sup>) was nevertheless able to differentiate those whose quality was no better than Free Gallipoli or Gluyas. Just as importantly, it could be performed quickly and easily on small amounts of grain, amounts that could be taken from rod rows (5½ yards—about 5 metres) and still leave enough grain for replanting if the line passed the test. For example, in 1934 poor quality Gallipoli gave a test of 30 mins and Gluyas 41 mins, whilst the better quality Ford went 73 mins.<sup>32</sup> A. R. Hickinbotham, chemist at Roseworthy and K. Woodroffe, cadet, were involved in this work.

All College graduates after 1934 and before 1970, when the Pelshenke Test was abandoned in favour of more specific tests, will have experienced the work entailed, as it involved a number of persons all working smoothly as a team to get the tests done. Briefly, the test involves recording the time taken for a small leavened ball of dough to disintegrate under controlled expansion caused by the gassing of the yeast within it. The team comprised a miller who prepared the wholemeal flour, a weigher who weighed up the 5g lots of flour, a pipetter who added the standardised yeast suspension, one or two mixers who mixed the water, yeast, flour into a dough, one or two kneaders who worked the dough balls after mixing, a time keeper who timed the balls into the water bath and their disintegration, and a washer-up who kept the water bath at constant temperature, and emptied and replaced beakers and petri dishes.

The equipment still exists but its only use now is to provide beakers for the occasional office party, and rather than being used for 'skulling' slippery oyster-like dough balls, as sometimes occurred, they are used to skull the products of another cereal.

# PURE SEED PRODUCTION ROSEWORTHY COLLEGE

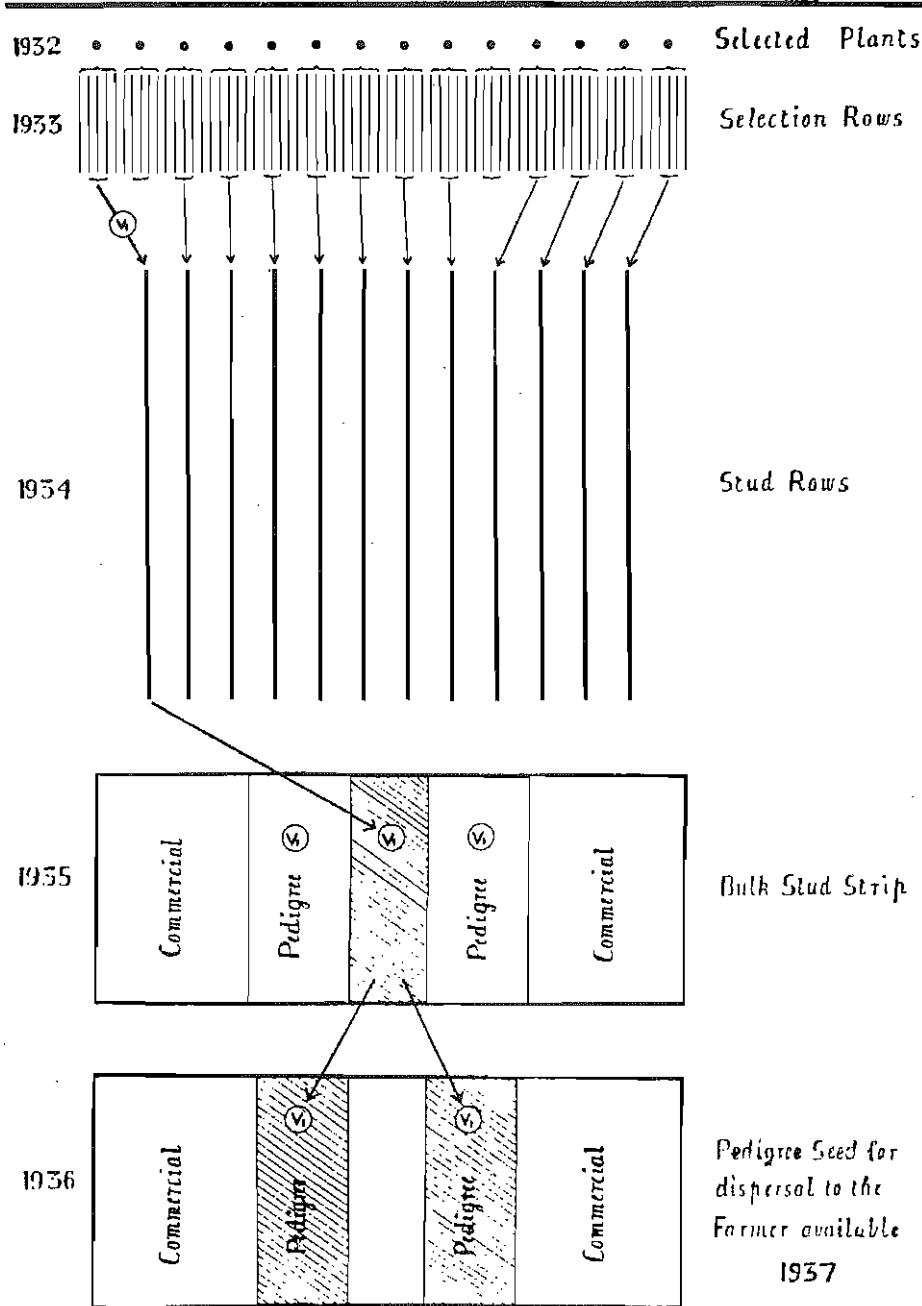

Figure 4: Pure Seed Production, 1933. *Journal of Agriculture* July 15, 1933, p. 1349.

This increased emphasis on quality meant that if there were to be no decreased emphases on other objectives, such as suitability to the environment, drought resistance, early maturity, and disease resistance, there would need to be an accompanying increase in the total number of lines under test. A larger number of crosses than previously were made. In 1934, over 8,000 F<sub>3</sub> and F<sub>4</sub> lines were tested for Pelshenke Times. This rose to 12,000 in 1935.<sup>33</sup> The grain for these tests came from 12,000 or more hand planted rows each 20 feet long with seeds at 3 inch spacing. In 1935 a student calculated that the hand planted rows stretched for a total of 53 miles (85km).<sup>34</sup>

Callaghan and Breakwell<sup>33</sup> travelled extensively and published many articles in order to allay any suspicions that farmers had that 'the College was paying attention to breeding of better quality wheats to the detriment of other objectives', particularly yield, and to convince farmers of the long term damage they would do to the industry by continuing to grow weak quality wheats.<sup>35 to 39</sup>

The true test of the baking quality of a variety is to bake a loaf of bread. To enable this final evaluation to be carried out on advanced lines near their time for release, a full test baking laboratory was built up between 1934 and 1936 in a converted shed. Some of the equipment was donated by the Millers Produce Company of SA Ltd.<sup>30</sup>

Further attestation to this commitment to quality was a purging of all weak flour wheats from the College programme, including the pure seed programme. Distribution of seed of poor quality varieties (Free Gallipoli, Ghurka, Penny, Gluyas Early and Waratah) ceased, maybe resulting in some loss of revenue.<sup>37</sup>

At this time, the College breeding plots were amongst the most numerous in Australia, as they remain today. The operation of these plots at a College which has abundant land in typical wheat-growing country, is naturally a fairly labour-intensive process. However, as Callaghan stated, the College has '... a good supply of student labour without which the expenses of the work would be greatly increased'.<sup>37</sup> It is not simply a matter, however, of cheap labour, for, as Callaghan states in a separate article 'students benefit considerably by constant contact with the work ... [which] their labour makes ... possible'.<sup>39</sup>

The students, at least at the time, had a somewhat different viewpoint:

The plant breeding plots in 4a retain their same accursed immensity... As Christmas approaches there always appears to be some trepidation amongst students and Plant Breeding Staff alike, as to whether the harvest from '4' will be off in time for a short vacation... The plots again eclipsed the record of size, much to our disgust, and large numbers of crossbred strains were given their field trials... [There has been] installation of new baking equipment ... and the laboratory is now resplendent with mills, oven, fermentation cabinet, mixer etc. 'Plant Breeding' might have its compensations in the future if students are asked to participate in tasting tests. Some of us are rather partial to hot crisp loaves but complications such as nabbing butter from the table and ultimately a refresher course in milking may result.<sup>40, 41</sup>

However this same student article did have much to say about promising crossbreds, Onas × Nabawa, Gluyas × Egyptian 4 and others.

In order to speed up the programme and to enable selection for rust resistance a 'bird cage'—a substantial cage to keep birds out—was built, and Breakwell grew F<sub>1</sub> and other selection material during the summer.

To help with this new, ambitious breeding programme, other professional expertise as well as simply more pairs of hands, was required. An assistant plant breeder—E. Mark Hutton—was appointed in 1936. S. R. Klose had already been a field officer in the programme for the previous two years. R. H. Jones was a field officer for a time (1935–39), and R. C. Hay was cereal cadet during 1935 before they transferred to other sections of the College. D. H. Mellor was Plant Breeding Cadet before 1938 and Field Officer in the breeding team until being transferred to run the farm in 1947.

It had long been realised that varieties performed differently relative to each other in different districts and that varieties selected at Roseworthy were not necessarily the most suited to other areas of the state. Perkins encouraged farmers to run trials with Department of Agriculture help to aid in choosing varieties. With the arrival of Hutton it was possible to extend the testing of advanced unreleased lines to other sites. The College collaborated with a number of farmers in this work—Smith Bros. at Yeelanna, A. M. Kelly at Urania, Ryan Bros. at Mundulla, T. Orrock at Wepowie and J. Cass at Pyap.<sup>42, 43, & 44</sup> This wide-scale testing gave very valuable information on adaptation especially when the early generation F<sub>4</sub> drill strip yield tests were extended to those outside sites in 1938.<sup>45</sup>

Hutton's major interest in wheat appears to have been its value as a staple food for the human race. He delivered some radio talks and addressed women's meetings on wheat as a foodstuff,<sup>46, 47, 48</sup> and thus it was natural for him to take a major role in quality testing and selection although one cannot be involved in a breeding team without becoming involved in all its selection objectives. With the newly-equipped cereal chemistry

laboratory Breakwell and Hutton extensively researched quality parameters of South Australia's wheat crop. They studied weathering effects,<sup>49</sup> protein variation across district and season,<sup>49, 50, 51, 52</sup> and the inheritance of quality.<sup>51</sup> The South Australian Department of Chemistry, especially its cereal chemist, A. R. Farquar, collaborated in this work. This association with Farquar had important implications in the 1940s and 1950s.

As a result of these specialist studies, both Breakwell and Hutton were awarded Masters degrees. Their data are still worth reading today by anybody at all interested in the wheat industry.

Throughout the 1930s there was a dearth of varieties released but there was no lack of activity in the breeding programme. This time lapse illustrates the lag which exists between the moment of embarking on new, extensive objectives and the time at which the work bears fruit in new improved varieties. The nett result of this building-up process, as Breakwell called it, was a batch of multiple crosses in 1937 containing four or more parents, a top cross with a suitable variety or some other complex cross.<sup>44</sup> Two such crosses, for example, were [(Nabawa × Egyptian 4) × (Kenya Crossbred × Bobin)] to combine quality, prolificacy and Flag Smut resistance from the first part of the cross with Stem Rust resistance from the second half; and [Nawab × (Nabawa × Bunyip) × Eureka] which too should combine baking quality, drought resistance, yield potential and resistance to Stem Rust and Flag Smut. Whether a combination of these characters would be recovered time would tell, but providing that selection techniques were appropriate and properly applied then improved varieties should result.

In 1939 Breakwell's first variety was released. This was one selection of 50 from Sword which he had taken soon after starting at Roseworthy and which, after passing through his many tests, proved superior to Sword in all respects.<sup>53</sup> Because it was, as he put it, a finer type of Sword he very aptly named it Rapier. Compared to Sword, Rapier was one week earlier, had outyielded it for 4 years, possessed better, finer and stronger straw, shattered less, had better baking quality and was resistant both to Flag Smut and Stem Rust. It was, incidentally, this decision by Breakwell, that is, the naming of Rapier from Sword, which established the tradition at Roseworthy of naming new College varieties after weapons.

The release of a new variety causes considerable excitement not only in the breeding team (who, as it were, sweat blood) but also amongst the general College community. *The Student* records in December 1938:<sup>54</sup>

Rapier appears to be the password in the plots, and a discussion on this new wheat has much the same beneficial effect on work marks as does a discourse on racehorses in the garden

Later, in December 1939, in reference to the weapon naming system, *The Student* notes:<sup>55</sup>

... if you hear of wheats such as 'Kris', 'Assegai', 'Hotchkiss', etc. after you leave the College you will know where they were bred. In the event of releasing a large number of wheats we hope they won't have to resort to names such as 'Magnetic Mine' or 'Mustard Gas'.

Our centenary year students make the same comment and feel the same excitement, but they have suggested more contemporary names such as 'Bike chain' and 'Exocet'.

The enthusiasm of Breakwell and his team never flagged and the breeding programme continued to develop into the 1940s. As the programme became larger, mechanisation needed to improve. It did, but not as fast as students would have liked, as recorded in *The Student* in 1938:<sup>54</sup>

One good piece of news that we can pass on is the contemplated purchase of a rotary hoe for plot work. This machine will replace the Planet Junior cultivator, that iniquity which is preceded by a horse and pushed by a student. Further enquiries regarding the rotary hoe, however, revealed that it has its limitations, for it will neither plant the hand sown plots nor hoe between the rows.

It was used for squaring off the ends of plots, a process now carried out with a shrouded boom spray using one of the dessicant or all-purpose herbicides. Hand planting, a task which never enthused anybody, was an essential part of early generation selection work,

simply because there was not enough seed from single plants to put through seed drills. That notwithstanding, it was work which raised student passions, again as recorded in *The Student*, in 1940.<sup>56</sup>

The plant breeders report that their beloved breeding plots got away to a flying start this year and that the hand rows were seeded in record time. No reference was made to broken backs, excessive blood pressure in the head and permanent crippling of the trunk; not to mention the unspeakable slander which rained upon wheat varieties plus their originators.

Hutton, who had become full time cereal chemist, left the College in 1941 for the CSIRO. To prevent the quality testing from dropping into the doldrums, A. R. Farquar at the SA Department of Chemistry carried out baking tests on the leading crossbreds. Farquar himself was a very imposing and dominant personality and in later years when it was necessary to enhance cereal testing facilities in this State he argued very strongly against duplication at Roseworthy or anywhere else. Consequently new equipment and expertise were installed in Adelaide in the Department of Chemistry to test for quality the wheats from the Department of Agriculture variety trials as well as Roseworthy's crossbred material. This situation still exists today, and although it has advantages in that quality testing is performed by an unbiased, independent agency, it has its disadvantages in that the breeder has no control over costs of the testing, especially since the College is no longer a State Government Department.

Two other wheats in the weapon series were released in the early 1940s—Scimitar (1941) and Javelin (1942). These were chosen from a number of promising crosses made between 1930 and 1934. Their pedigrees are Nabawa × Egyptian 4 and Onas × Nabawa respectively. Onas was crossed with Nabawa on 16th October, 1930 at the suggestion of Spafford, who, although then Director of Agriculture, was maintaining his interest in the wheat breeding at Roseworthy. Nabawa was crossed with Egyptian 4 on 18th October with the expressed purpose of combining the Flag Smut resistance of Nabawa with the earliness of Egyptian 4. A better quality variety also resulted. It should also be noted that Scimitar, as an unnamed crossbred, had been used in multiple crosses as early as 1938.

Soon after Professor A. E. V. Richardson became Director of the Waite Agricultural Research Institute, I. F. Phipps commenced wheat breeding there. Disease resistance became an increasingly important aspect of his breeding, and in response to a request for more help and the need for more plant pathological expertise, Dr Albert T. Pugsley was appointed. The inheritance of resistance to several diseases was studied, and the lack of good disease-resistant varieties for local conditions was recognised. Pugsley became disenchanted with the pedigree method of breeding because of the ineffectiveness of selection based on single spaced plants, caused by the tedium of collecting vast amounts of information, and the difficulties with respect to facilities of assessing regional adaptability of new selections. He felt that it was better to take the proven varieties representing the painstaking efforts of breeders of past years and by a backcrossing technique incorporate one or two specific genes for disease resistance, without disrupting their adapted background, which would have required extensive selection and testing.<sup>57</sup> Of course, he did not have the land and labour which was available at Roseworthy.

Thus there existed during the 1930s and 1940s two breeding programmes, each with very different philosophies and somewhat different objectives. Friendly rivalry existed between the breeders Pugsley and Breakwell and they collaborated frequently. Pugsley chose Scimitar, Javelin and Rapier, Roseworthy varieties already being grown by farmers, as some of the recurrent parents for his backcrossing programmes. From these he released Scimitar 48, Javelin 48 and Rapier 48, each similar to their original Roseworthy parent but with the added advantage of possessing the Gabo gene, Sr11, for Stem Rust resistance. These varieties were released in 1948 and largely replaced their parent varieties in farmers' fields.

During 1942 Breakwell enlisted in the AIF where he quickly became Captain of the Transport Section at Sandy Creek and eventually reached the rank of Major. To enable

the reduced labour force at the College to cope, the wheat breeding programme was reduced considerably during his absence. Mellor performed all the field work and Pugsley came up from the Waite Institute to give lectures, help with the harvest and to perform selection work. In 1942 the programme was reduced to 1,400 hand rows, 44 drill strips and 112 1/40th acre plots. Outside sites were discontinued. In 1943 the programme was down to 460 selections.

In exchanges of seed between Pugsley and Breakwell, Pugsley chose an advanced line from several from the cross Ford × Dundee as having good potential and used it in his backcross programme in 1942. It was his practice to test selections after each backcross but still to perform more backcrosses. Selection 5 from this cross, unofficially named Dirk in 1946, was backcrossed one, two and three times using Gabo as the donor parent for Stem Rust resistance. Whilst a second backcross derivative was being tested at Saddleworth, F. W. Coleman, the property owner and a keen selector of wheats, noted its potential. He proceeded with seed increase and in about 1949 distributed it to farmers.<sup>57</sup> It continued to do well and was commonly known as Gabo 3 Dirk. In about 1957 Coleman named it Aldirk (in reference to Albert Pugsley's Dirk). Along with other Dirk derivatives, it was still being grown in the mid 1970s but has lost popularity rapidly since about 1975 because of better varieties and rust susceptibility.

Dirk itself was never officially released to farmers by Roseworthy but it was registered by Breakwell so that Pugsley could release his Gabo × Dirk<sup>4\*</sup> as Dirk 48, thus giving due recognition to it as the recurrent parent. In fact the seed multiplication years of Dirk in 1946 and 1947, just prior to its likely release, were serious rust years and, in 1947 the crop of Dirk in College paddock S3 was a total failure. Dirk 48 (as well as Dirk and other derivatives) had excellent baking quality, and it was strongly supported as a replacement for Insignia and Gabo by the South Australian Committee for Wheat Improvement.<sup>58</sup>

Dirk 48 was very popular on the Adelaide Plains and other red-brown soil country. Pugsley subsequently produced other important varieties—Yande (1951) and Raven (1961)—from it, as backcross derivatives. It has demonstrated good combining ability with the Mexican semidwarf wheats, to produce Warigal (1978) and Aroona (1981) by Rathjen of the Waite Institute and Lance (1978) at Roseworthy. Yande was to have been named Dirk 51 but changes to the rules for the nomenclature of wheat varieties prevented number suffixes from being used. Professor Prescott and Pugsley named it Yande, after an Aboriginal barbed spear to indicate its Roseworthy origins. Yande had both Stem Rust and Bunt resistance, as did Raven.

Breakwell quickly revived the breeding programme when he returned after military service, and although 1944 was a drought year and low yields were obtained, third year students were comforted by the fact that '... the plots would be back to their pre-war size and there will be ample opportunity for incoming First Years to acquire skill in that intriguing game known as three inches apart'.<sup>59</sup>

There were 7,000 hand rows in 1945! Unfortunately, '... magpies undid much of the good work of the toiling first years (and second years) by carrying a blitz on late germinating material. They at least, appear to appreciate the quality of Roseworthy wheats'.<sup>60</sup>

Jack V. Mertin commenced work as assistant plant breeder in 1945 and initiated an oat breeding programme (discussed below) before he changed careers to horticulture in late 1947. E. N. (Ted) George joined the plant breeders as field assistant on the transfer to the farm section of Fred Hillman, who had spent some time in the breeding team during his long period at Roseworthy, whilst the plant breeding cadet at this time was J. T. Southwood.

\*This refers to 4 crosses of Dirk (i.e., Dirk × Dirk × Dirk × Dirk) crossed with Gabo, and is not to be confused with reference number 4.

Ted George was noteworthy partly for an unusual attempt at solving a very practical problem. At the beginning of seeding a record number of plots in 1946, Ted George had trouble handling the horses which pulled the drill because of his '...purity of expression'.<sup>61</sup> The horses, it appears, had been used to Fred Hillman's 'grotesque descriptions of their pedigrees'<sup>61</sup> and 'loud exhortations'<sup>61</sup> to make them walk in a straight line. Ted overcame this problem by the introduction of an elaborate bombsight on the front of the drill.<sup>61</sup>

The year 1946 also saw some very important steps taken for the future development of the science of plant breeding. At the 26th meeting of the Australian Agricultural Council in February 1946, a resolution was passed that a conference of cereal plant breeders and geneticists be held in South Australia under the auspices of the Australian Agricultural Council to coincide with the August 1946 meeting of the Australian Institute of Agricultural Science. The request for this meeting was from a joint submission drafted by Pugsley and Breakwell. The first Australian Conference of Cereal Breeders and Geneticists was held at Roseworthy Agricultural College 15-16 August, 1946. In all 19 delegates met for the two days. This was the first formal meeting of wheat breeders since the 'Rust in Wheat' meetings of the 1890s and it set the precedent for other technical conferences sponsored by the Agricultural Council which have contributed greatly to exchanges of ideas and thus the advancement of agricultural science in the last 37 years.<sup>57</sup>

Breakwell, a jovial character with many abilities which led him to accept many responsibilities at the College whether as plant breeder, senior lecturer in Agriculture, or participant in sport, was passed over in the 1940s for appointment as deputy principal. To further his career he resigned in 1947, and went to the Sydney University School of Agriculture taking with him his knowledge, philosophy and wise counsel. He will always be recognised for his efforts in combining high yield and baking quality.<sup>62</sup>

His place was taken for a short time by A. J. Millington, a South Australian who had graduated in Western Australia and with the wheat variety Bungulla already to his credit. He extended the testing beyond Roseworthy and replicated trials were sown in 1948 at Balaklava on the property of G. May, in order to get data on the relative merits of crossbreds under dry conditions.<sup>63</sup> The previous off-College sites had been performed using the farmers' equipment, but Balaklava was sown and harvested by College staff. Ted George used to tow the equipment up and back behind a tractor.

### *Krause, 1950s and Quality*

Millington went back to Western Australia in 1949 and his place was taken, supposedly temporarily, by M. Rex Krause who was transferred from his position as Assistant Biologist.

Krause, who had been on the College as a staff member for about a year, had just graduated in Agricultural Science from Adelaide University. Prior to going to university he had been Dux of agriculture and graduated with first class honours at Roseworthy in 1943. His abilities stretched to the sports field, where as a student he was champion athlete of the College and captained both the cricket and football teams. He continued in the latter sport for many years whilst on the staff.

Krause took to the work with versatility and enthusiasm and became the permanent plant breeder, he and Ted George carrying the programme, with the help of students, from strength to strength. With his zeal and characteristic happy whistling and no less arresting laugh he instilled confidence and trust.

When small rust pustules were found on the '48' wheats in 1950, Krause became quite concerned because his material under test at that time consisted almost entirely of crosses using the '48' type resistance (gene Sr11) from Gabo. He was especially concerned about five advanced lines which he was hoping to release. Fortunately the fear was groundless



because the rust was diagnosed by Waterhouse as being the old race. The new Gabo attacking race reached South Australia a few years later in 1956. One of these lines, RAC154 [(Gabo × (Nabawa × Dan × Dundee)] × [Dundee × Kenya C6042] was released as Sabre in 1952. Another promising crossbred, RAC20, Gabo × (Dundee × Caliph), was released in 1956 as Claymore although it was almost rejected in 1954. These results of Breakwell's complex crossing programme, discussed earlier, further illustrate the time lag between making the cross and releasing an improved variety: the two crosses above were actually made in 1940!

Krause continued testing at Balaklava for a few years and extended this off-College work to include a low rainfall, lighter soil area at Palmer. Trials were carried out on his family farm which he not only knew intimately but also which he felt represented a large area of the South Australian wheat growing belt. The most promising advanced crossbreds were also tested by the Department of Agriculture at a number of other sites. Krause introduced a wheat crossbred register into which promising fixed crossbreds were entered and given an RAC number. This register is still in use, the last entry in 1982 being RAC1494 selected from the cross (Gamenya × 8156) × Toquifen made in 1975.

The efforts in improving Australia's wheat for bread baking purposes, as noted above, had been very successful in South Australia. In 1932, Förd, the only popular variety classified as medium strong, accounted for only 4% of the harvest whereas in 1952 51% of the area was devoted to medium to strong varieties.

Formal variety recommendations were not made by the Department of Agriculture until 1957 but results of replicated variety yield trials had been published since their inception in 1948.<sup>64, 65</sup> In these early recommendations, high yielding but lower baking quality varieties were not advocated because their admixture with strong wheats would spoil the marketable grain.<sup>66</sup> Breeders responded to this aim for improved baking qualities by keeping only vitreous grained selections in their programmes and by selecting for high Valorimeter figure.\*

Callaghan<sup>62, 68</sup> suggested segregation of the better quality wheats from the FAQ class into a Strong White class. This eventually came about for the 1957/58 harvest and after several successful seasons became established as a good yet simple marketing technique. Today, Australia's wheat is classified into five main classes—Prime Hard, Hard, ASW (Australian Standard White), Soft, and Durum—based on the experiences of that original segregation.

After several years when it became apparent that the segregation system was successful, high yielding poorer baking quality wheats, such as Insignia 49, could be recommended for sowing,<sup>69</sup> especially in those areas where they performed well and where, because of climatic and edaphic conditions, hard wheats were seldom of sufficient protein content to make good baking quality, or they mottled.<sup>70</sup> Variety recommendations are now considered and decided by the South Australian Advisory Committee on Wheat Quality, set up in 1962. This change in attitude to quality left South Australian breeding programmes deficient in high yielding FAQ type wheats. Selection for high Valorimeter figure, advised by Farquar, also led to hard wheats with tough overstable characteristics which were not of particularly suitable quality at low protein levels. These two points dramatically set back varietal improvement in South Australia in the 1950s and 1960s, and, in fact, tough and too-hard lines of wheat still hamper present breeding efforts when using Roseworthy germplasm originating from this era.

### *1960s—Enhanced Programme*

Enthusiastic plant breeders always have advanced lines under consideration for release. Unfortunately most of these lines do not pass the critical evaluation necessary before

\*The Valorimeter figure is a single figure read from Farinograph data and takes into account all aspects of the dough.<sup>67</sup>

release. They may fail in any one of the many requirements needed in a new improved variety. Sometimes this failure is due to changed growing conditions (e.g. new disease strains), or to changing market demands or, most frequently, to inappropriate and inadequate objectives and selection techniques. These latter problems are usually due to insufficient facilities which prevent the pursuit with any certainty of a complex set of objectives. So it was with Krause, who was elated at one moment by the outstanding yield performance of some of his crossbred selections only to be frustrated later when they were found deficient in other characters. RAC200 (Gabo × Dundee × Caliph × Bencubbin) and RAC302 (Javelin 48 × Insignia) were two such promising crossbreds which were withdrawn because of a lack of Stem Rust resistance after a late outbreak of rust at Palmer in 1959.<sup>71</sup> Another, RAC400 [Sabre × (Gabo × Sword × Dundee × Bencubbin)] showed up well in dry seasons but not in better years. RAC520 (Claymore × Festival) and RAC525 [(Dundee × Ghurka × Kenya × Ford) × Festival] had drought resistance and Stem Rust resistance, but were too hard grained. All of these wheats entered large seed multiplication areas with a view to release.<sup>72</sup>

All of these various difficulties could be overcome, Krause argued, if the wheat breeding work were enlarged. With the passing of the Wheat Research Act (1957), financial assistance from grower contributions to wheat research became available and the envisaged enhancement became possible. Peter Gratton, RDA, was appointed as Pure Seeds Officer in 1959 to take over responsibility for maintenance, multiplication and distribution of seed of wheat and oat varieties recommended for sowing in South Australia. His place was taken in 1960 by Ross J. Ford. Equipment which seems so basic to agronomic research, such as a tractor, seed drill, grain mill and an equipment shed were purchased with this source of funds. However, Krause's desire to breed more effectively for better adaptation by establishing a substation in the low rainfall areas of the wheat belt for selection and testing was not realised until an assistant plant breeder, Gil J. Hollamby, author of this present chapter, was appointed in late 1961. The programme put into effect at that time is shown in Figure 5.<sup>73</sup> The breeding objectives were to produce high yielding, adaptable varieties combining high protein content with a medium to medium strong well balanced flour, free of mottling tendencies, resistant to Flag Smut, preferably with some resistance to Stem Rust and agronomically sound. Specific modifications such as early maturity and drought resistance for the lower rainfall areas, and the possibility of high yielding softer varieties for the better districts were being considered.

I was a raw graduate from the Waite Agricultural Research Institute, where I majored in Entomology and Genetics, and later audited the Plant Breeding lectures at the Waite Institute during my first year on the staff at Roseworthy. Working in close contact with Dr Keith Finlay, then Senior Plant Breeder at the Waite, led me to a clear understanding of his philosophies about the need to widen the genetic diversity in breeding programmes within Australia and the need for large scale field trials to assess selections

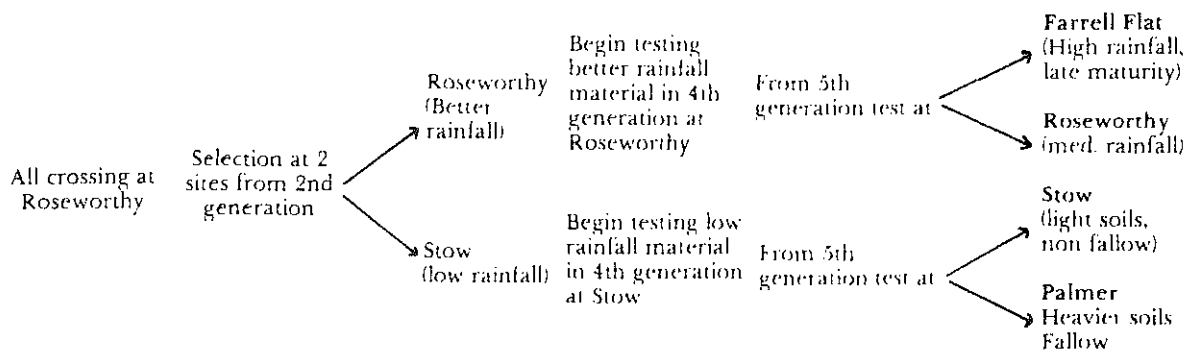

Figure 5: Selection Programme implemented 1961. *The Student* (1963):12.

for yielding ability.<sup>57</sup> Thus together in 1962, Krause and I made overtures about introducing exotic germplasm into the breeding material by making crosses between Australian and introduced lines obtained from Finlay. Wheats from countries of similar climate (e.g. Morocco, Portugal and Iraq) were used. These early crosses did not show promise but certainly demonstrated the extent of genetic variation available in wheat and the need for closely matching varieties to the environments in which it was intended they should be grown. To encompass the extra material coming forward plot sizes were reduced to 4 rows of 100 links (previously, 9 rows × 313 links), a new stripper, side mounted on the tractor, was built and the seeder was modified to sow more plots per day. Ted George readily oversaw this expanded field programme and every day could be heard whipping students, staff and breeders into gear.

Apart from this work, George will also be remembered for his practical jokes, as well as for his gentle management of the plant breeding group's unpaid staff member, known as Ted Cat or Chunder Cat, whose job it was to keep the seed store mouse free but who was always too well fed to care. Many students will also remember what was known as Ted's Circus, consisting, at seeding time, of the tractor driven by Ted George, one or two trailers and seeder with students at the back, or, at harvest, of tractor, stripper and one or two trailers. Unfortunately George was forced to retire early in 1969, because of a physical disease acquired during war service.

By 1963 semidwarf spring wheats from Dr N. Borlaug's programme at the International Wheat and Maize Improvement Centre, Mexico (CIMMYT) were becoming recognised in Australia for their yielding ability. Krause predicted that they could dominate the wheat scene in the future.<sup>73</sup> He travelled extensively in North America in 1965–66 after being awarded a William Farrer Memorial Scholarship, and inspected wheat breeding work in the USA and Mexico.

Most of his time was spent working at the Washington State University with Dr O. Vogel, who had introduced semidwarf wheats from Japan and used them to produce non-lodging semidwarf winter wheats especially suited to high nitrogen fertility. Whilst at Washington State University Krause made crosses between Australian wheats and semidwarf material which he had collected on his inspections, as well as completing a Masters Degree.<sup>74</sup> In his crosses, Mexican lines were mainly used because, being spring wheats, they are able to yield well in Australia especially in high soil fertility conditions. Most, unfortunately, were red grained and had other quality defects such as low flour extraction. Better quality semidwarfs from Utah and Minnesota were then used.

During the two years after his return, studies evolved to determine the best cross combinations by which to introgress the yield potential of the semidwarfs into Australian wheats without upsetting quality. Single, first and second backcrosses were made and selections from each were tested for yield and quality at a number of sites of high and low fertility. The first backcross to the Australian parent showed most promise and was used as the main method of breeding with this exotic germplasm. It was not until 1975 that a variety, Lance, was released from this work.

### \* The Halberd Story

Two crossbreds showing good performance in the early 1960s were RAC414 and RAC456. RAC414 (Gabo/Rapier/Dundee/Kenya//Dirk 48)\* was released in 1966 as Glaive because of its consistently good yields over a range of growing conditions and because of excellent baking qualities. Unfortunately the first year of its growing by farmers, 1967, was a severe drought year and it did not perform as well as the most widely grown but poorer quality varieties Insignia 49 and Heron. It never became very popular although it continued to perform well in Department of Agriculture trials.

\*In the 1960s, the old style of designation of pedigrees by means of crosses and brackets, as used earlier in this chapter, was replaced by slashes (/) to facilitate recording by computers.

Replacement of Insignia 49 and Heron became a very important priority for breeders because these varieties are very poor millers, the flour being, as it were, woolly and difficult to sieve.

In yield trials around this time there was an advanced crossbred known as RAC536. It possessed considerable Insignia 49 germplasm, its pedigree being (Scimitar/Kenya/Bobin)/Insignia 49, and it appeared to have some Stem Rust resistance and good milling qualities. It was morphologically similar to Insignia, being fairly short, strong strawed and with a brown chaffed head. Unfortunately it was up to one week later in heading. In 1961, however, an earlier selection was noted and entered into trials as RAC687. The wide adaptation and yield potential of this earlier selection were outstanding. They were approached only by another Insignia derivative, RAC662 (Sabre/Insignia/Javelin 48/Insignia) but because this crossbred had the so-called woolly flour character of Insignia 49 and Heron and no better rust resistance it was discarded. RAC687 was registered and released to farmers in April 1969 as Halberd.

Its registration was not without considerable trauma for Krause. Because of its extremely promising yields (in over 49 comparisons between 1964 to 1968 it performed 9.4% better than Heron, 13.6% better than Insignia 49 and 20.1% better than Raven) the Australian Wheat Board, guided somewhat by the attitudes of the Bread Research Institute of Australia, became concerned about its quality characteristics. It was a superior milling wheat with at least a 5% flour extraction advantage over Heron and Insignia 49 but it was achieving this in part because it was hard grained, and so lacked adequate dough extensibility particularly at low grain protein concentrations, when starch damage during milling would also be excessive.

Krause and E. H. Acton (Cereal Analyst, SA Department of Chemistry) convinced the SA Advisory Committee on Wheat Quality that its milling advantages and the need to replace Heron and Insignia 49 far outweighed the potential extensibility problem. They recommended that its segregation into the FAQ class, and not into the Hard class could be easily achieved because, as there were no brown chaffed Hard category wheats being widely grown, any grain loads delivered with brown chaff (chaff can always be found in corners at the top of loads) could be received only as FAQ. Registered seed wheat growers were provided with the 11.4t of Halberd seed available and 142 other farmers with requests had to wait until after the 1970 harvest.

From his meagre distribution in 1969 the promise shown in yield trials was realised in commercial plantings by farmers and the area sown to Halberd increased at a startling rate (see Figure 6) to reach 820,970 hectares or (56.7% of the wheatlands) in South Australia in 1973 and 763,046 hectares (62.0%) in 1974. It also rapidly replaced Insignia in Victoria where it was planted on nearly 500,000 hectares in 1973 and 1974. In 1977, when it was planted on 966,219 ha (9.7%),<sup>75</sup> Halberd was the second most popular wheat, after Condor, in Australia. It thus became the most important variety yet released from Roseworthy. Its selection history is detailed in Figure 7.

Plant breeders exist in a paradoxical situation. On the one hand they hope that their new variety will be successful and widely grown by farmers. Yet, on the other hand, they realise that the more widely accepted and grown their variety becomes the shorter will be its life because the greater is the probability that new disease strains will build up and render it highly susceptible.

So it was with Halberd. In 1969 when Halberd was released the main Stem Rust strain in South Australia was 21 ANZ-2, which attacked all varieties possessing only the gene Sr11, but to which Halberd was resistant. Halberd possesses Sr6 and Sr11 and was susceptible to the rare strain 21 ANZ-1, 2. During the period of rapid acceptance of Halberd, Stem Rust was a rare disease but where it did occur, race 21-1, 2 had a better survival rate than 21-2 because more and more crops were Halberd. Thus in 1973 when climatic conditions were conducive to Stem Rust infection and build up, a widespread epiphytotic of races 21-2 and 21-1, 2 occurred, and most varieties in South Australia,

Figure 6. Important Varieties in South Australia 1926-83 (Rosworthy Varieties shaded)

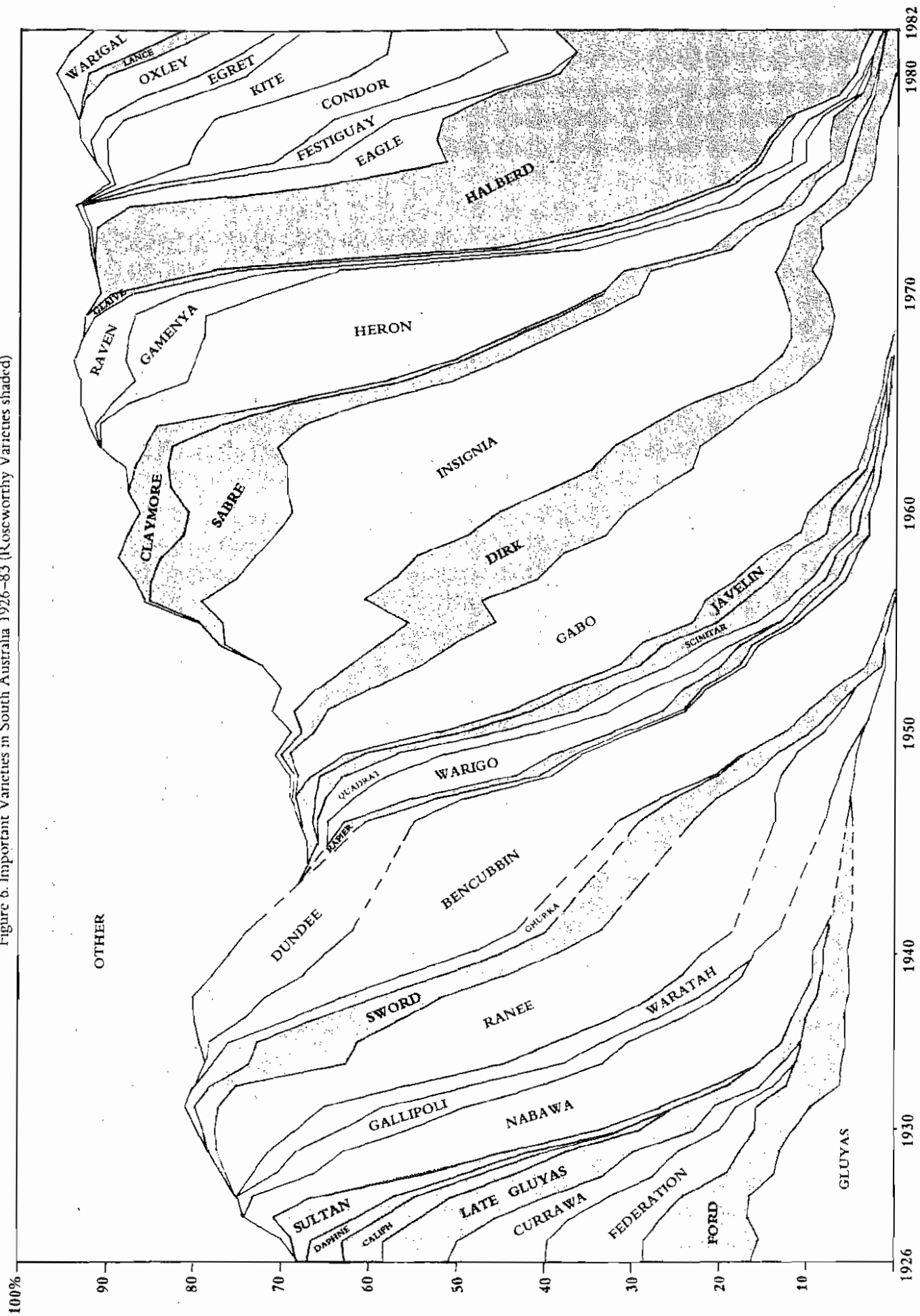
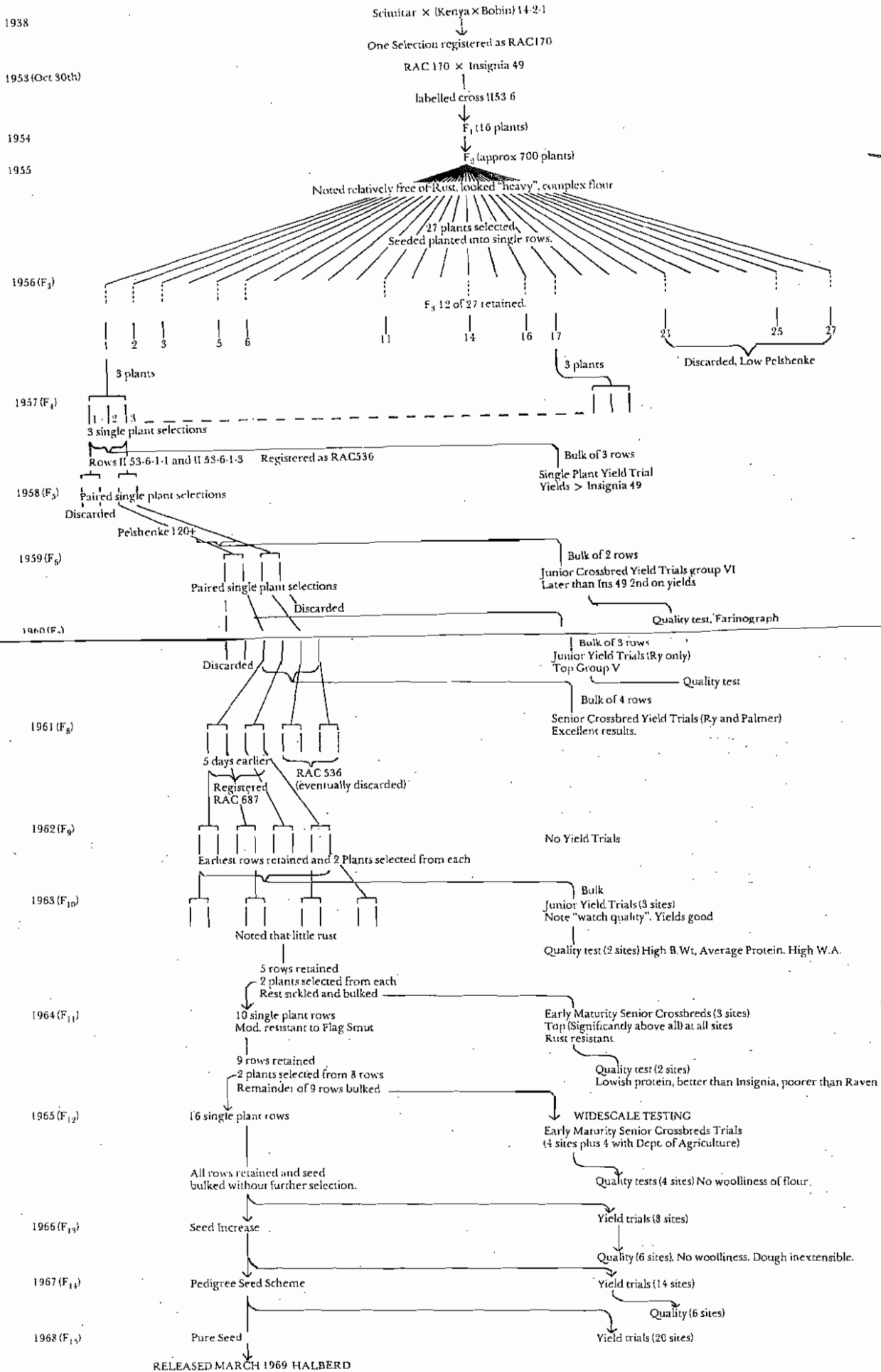

Figure 7: Selection History of HALBERD



including Halberd, succumbed. Conditions were favourable again in 1974 and farmers in South Australia and Victoria virtually lost their entire crops of Halberd. Farmers particularly in the areas more prone to Stem Rust urgently sought to replace Halberd and other susceptible varieties and because locally bred resistant varieties were unavailable, varieties were introduced from New South Wales and Queensland. These varieties included Festiguay, Eagle, Condor, Egret, Kite and Oxley. Other farmers in less rust prone areas were more philosophical and continued to grow at least some Halberd because of its superior productivity in the absence of foliar diseases, an absence which, on their farms, was the normal situation.

The area sown to Halberd thus dropped dramatically but has levelled out at around 30% of the area sown in South Australia. It is being regrown by many farmers in even rust prone areas because the replacement varieties such as Condor, Kite and Oxley have not yielded nearly as well in droughty conditions which are more a feature of the South Australian environment than Stem Rust conditions.

Nevertheless a more disease resistant Halberd derivative is continually being sought by farmers. Questions on this subject are probably the most frequently asked of all questions directed at the breeding programme. Halberd however, has not been a good parent in crosses so the approach has had to be to make several backcrosses between resistant donors and Halberd. The quality deficiencies of Halberd are likely still to remain in derivatives arrived at by this method. And, to make matters worse, Halberd was severely damaged in 1975 by Speckled Leaf Blotch.

The Halberd story is far from complete. Halberd is increasing in area in Western Australia where it has been recommended for some wheat growing zones since the enactment of variety control legislation which provided a means of discouraging its widespread planting by the application of discounted payments to growers growing Halberd in areas where quality deficiencies would be magnified. In South Australia it has largely replaced all other varieties in the Australian Standard White\* category—most of which were soft grained—and this has meant a marked change in hardness and marketability of the South Australian ASW. New markets specifically seeking this level of hardness may dictate a need to alter quality objectives for new ASW varieties in South Australia. Halberd has raised the milling standards of the harvest and has made it harder to match or improve upon with new varieties. The local milling and baking industries have learned how to handle Halberd flour, where to choose their wheat, and how to avoid sticky loaves because of too much starch damage with consequent high water absorption. They are thus able to make good bread flour from ASW at ASW prices. The reliable yield performance of brown chaffed Halberd, and, before it the brown chaffed varieties Heron, Insignia 49, Ghurka, Rancee and Free Gallipoli, have led farmers in Southern Australia to associate yield and adaptation with brown chaff and many farmers will not try a new variety unless it is brown chaffed. The association is, I believe, fortuitous as all the wheats mentioned are related by descent and have acquired brown chaff as well as high yield potential through this line of descent. Many other brown chaffed wheats without such high yield potential have been bred but naturally they are not remembered.

### *Improving the Programme (Developments in the last 20 years)*

Just before his overseas study leave Krause had been appointed Vice Principal and after his return the duties of this position took him further and further away from the wheat

\*In the 1974/75 season the FAQ and Semihard classification of wheat used for marketing was changed and the FAQ (Fair Average Quality) was renamed Australian Standard White (ASW). The semihard became Australian Hard. Premium soft wheats suitable for biscuit making are now segregated as Australian Soft, whilst hard wheats of good quality and high protein are segregated in New South Wales and Queensland as Australian Prime Hard. Further, legislation operative since the 1980/1 season to help maintain the marketable quality of Australia's wheat harvest allows for discounting below ASW prices if specific varieties are grown in areas in which they produce unacceptable quality.

breeding work. However his heart was still with cereal improvement and to get back into this research as well as to see to the secondary and tertiary education of his family he took the position of Principal Research Officer (Agronomy) in the South Australian Department of Agriculture and moved to Adelaide in 1972. Through his contributions on various committees and his oversight, with T. G. Heard, of primary and secondary trials of wheats into which many Roseworthy crossbreds are promoted, he still maintains an active interest in the work.

Although the objectives of the wheat breeding programme have become more complex, and the breeding methodology changed since 1972, the work with semidwarf wheats which Krause introduced to Roseworthy has continued. Lance, released in 1978 as the first semidwarf wheat released by Roseworthy, was selected from the cross Collafen × Raven. Collafen, the semidwarf parent of Mexican origin, was received from Chile from an old student. Lance was released as a soft grained ASW quality with high yield potential and improved Stem Rust resistance over Halberd. Unfortunately its yields have been somewhat unreliable and it is susceptible to Stripe Rust, a disease first recorded in Australia in 1979. Interestingly it is not bearded, unlike most semidwarfs.

Many other crossbreds resulting from Krause's first wave of Australian × Semidwarf crosses have been recycled as parents to give a continuous and recurrent upgrading of Roseworthy's breeding germplasm. One of these of current interest is RAC177 (Mexico C3/2\*Gabo). Mexico C3 (Sonora 64/ /Tezanos Pinto Precos/Yaqui 54) was selected by Krause from single plant rows whilst visiting Borlaug in Mexico, 1965. Many lines derived from RAC177 or Mexico C3 have reached wide-scale field trials, and whilst many have been discarded on the basis of red grain or other quality defects few have been abandoned on yielding ability.

When crosses are made involving parents which are completely unrelated, such as was being done with introduced semidwarfs and local material, the number of new and often undesirable genetic variations produced is very large. As a consequence, more selections need to be carried out. Particularly important were the quality defects introduced (red grain, poor milling and baking quality) and the unknown characteristic of adaptation\* possessed by the semidwarfs which overseas had been selected for conditions far more favourable than those found in South Australia, often for irrigation and high fertility situations.

Accordingly it was essential to upgrade quality and yield testing facilities to enable assessment of more selections. A protein analyser using the dye binding principle<sup>76</sup> was purchased to enable protein contents to be determined, and the Zeleny Sedimentation Test<sup>77</sup> was used in conjunction with the Pelshenke Time to assess quality. Selection rows sown with seed from single selected plants were now being sown mechanically rather than by hand, using a magazine-loaded piston-regulated seeder designed at the Waite Institute and adapted to 3-point linkage at the College in 1963. From 1967, seed for yield trials was prepared in packets in sowing order, one packet per plot, the seed being distributed to the four sowing tynes as the packet was poured into the seeder at the beginning of each plot. Single plant selection characteristic of the pedigree breeding method was discontinued beyond the F<sub>4</sub> generation to allow more time to be spent on more lines. A self propelled 1.25m header-harvester replaced the stripper harvester in 1968. Plot sizes continued to decrease to allow more to be tested. In 1968 the present Plant Breeding Centre was occupied and gave the wheat breeders properly equipped cereal laboratory, seed storage, and grain processing areas for the first time. Previously the laboratory had been the main room of the College infirmary building, the breeder's office had been the matron's office, and the seed storage and processing area was a large

\*This inexplicable background adaptation acquired by Halberd from its Australian ancestry (popular varieties such as Federation, Gabo, Gallipoli, Insignia, Purple Straw and Ward's Prolific are in Halberd's pedigree) but not possessed by Condor or Oxley which have very little Australian germplasm probably accounts for Halberd's reliability over an extreme range of growing conditions and thus its continuing popularity with farmers.



bird-proof barn which often became infested with weevils. A laboratory assistant, Miss P. Heggie, was appointed on Wheat Industry Research Funds in 1970, to perform early generation quality tests including a milling test with a Brabender Quadrumat Junior Mill.

Field operations as well as laboratory operations continued to be labour intensive and students on farm practice were heavily relied upon to get the breeding work done. Of course, as noted earlier, close student contact with staff gave the opportunity for students to gain useful information, for example, about important experiments on genetics, yield components and breeding methodology.

I attended a plant breeding refresher course during 1966-67 at the CSIRO, Canberra, where there was the opportunity for an introduction to computer programming, and since 1967 the plant breeding work, especially the mundane aspects of trial plans, field books and statistical analyses of data have been computerised. A thesis on genotype-environment interactions in wheat breeding<sup>78</sup> commenced at this time led to an award in 1974 of a Masters degree in Agricultural Science by the University of Adelaide.

Field mechanisation is still continuing and very few of the techniques of even ten years ago are now employed. Header harvesters with 1.25m combs, capable of operation by one person, are the main harvest equipment for yield trials. Seeders and plot shapes have also continued to evolve. Much of this field work and the innovations involved can be credited to field staff, J. (Jim) Loller (1969-73) and subsequently A. John Menzel (1974-). Pat Heggie, the first laboratory assistant, was succeeded by Miss Robyn J. Lienert in 1974, who has continued to improve the laboratory procedures of the programme. An assistant plant breeder, John Jennings, was appointed in 1972 but he transferred to teaching activities elsewhere on the College in 1974.

When the College became a College of Advanced Education in 1974 it was unable to fund non-educational pursuits—including plant breeding—using its normal funding grants, as it had been able to do when it was a Department of the State Government under the Minister of Agriculture. However, the first Director, Dr D. B. Williams, could see the importance of the wheat breeding programme to the College because of its educational value to students (as a resource base for agronomy, biometry and cereal chemistry, as well as by the additional credibility that an on-going research programme lends to teaching) and as a means of bringing farmers into contact with the College. He was also sympathetic to plant breeding from his experience as an undergraduate student at Sydney University under Professor W. L. Waterhouse. As a result of his negotiations, key staff in the programme are now funded from South Australian Government sources through the Minister of Education after additional consultation with the Department of Agriculture and the University of Adelaide. There has subsequently been a review of all field crop breeding conducted in South Australia which suggests the amalgamation of all plant breeding programmes into one establishment.<sup>79</sup>

In 1974 there were 3 full time staff in the programme—the author, who had taken over as Plant Breeder after Krause's resignation in 1972, Lienert, as Technical Assistant for laboratory work, and Menzel, previously a local farmer, as Field Assistant who performed, with the help of students, most of the field work over four sites throughout the State. Two years of serious Stem Rust outbreaks at the time caused farmers, wheat breeders and scientists to seek more active pursuit of disease resistance objectives in breeding programmes, but it was apparent that the staff were already fully committed to other objectives and would be unable to pursue new disease-resistance goals without reducing the work on yield, wide adaptation and quality. It was also of some concern that severe interruption could occur in the programme if the only qualified person familiar with the breeding material—myself—became unavailable, whether by resignation or incapacitating accident.

Accordingly two new appointments were made. Robin E. Wilson, a secondary school teacher who had majored in Plant Breeding and Plant Pathology as an undergraduate at

the Waite Institute, was appointed in 1975 as Research Associate. His presence and expertise enabled disease objectives to be pursued more actively. Initially work was commenced with Stem Rust and Speckled Leaf Blotch resistance, but it has encompassed Cereal Cyst Nematode and Take-all in more recent times.

Secondly, Ali Bayraktar, a wheat breeder in Turkey whom I met whilst on a study tour of wheat breeding centres in North America and Europe, was appointed as Assistant Plant Breeder in 1977. He brought with him several years' experience including post-graduate work in Oregon, USA, as well as germplasm from his previous programme and an intimate knowledge of winter wheats.

A technical officer was appointed with support of the South Australian Wheat Industry Research Committee to enable proper handling of the enlarged programme necessary to encompass more complex breeding objectives. Ray Brengman, a graduate from Kansas State University with experience in working for a wheat breeder in the USA held this position from 1976 to 1978. His contribution to the programme went beyond that of a technician and was more like that of a breeder, as he developed several backcrossing projects for Stem Rust and Speckled Leaf Blotch resistance and commenced work on a male sterility-facilitated recurrent selection procedure. He eventually became a sorghum breeder in Queensland. His position has since been occupied by Richard Leske (1978-80), Allan Hopkins (1980) and A. (Andy) J. Macleod (1981-).

Each of these persons has made different but significant contributions to the programme and in turn they have received experience in wheat breeding. Leske's insatiable capacity for physical work allowed the field programme to expand considerably, whilst Hopkins' knowledge of computing made some changes to data storage. Macleod's inventive ability has allowed better mechanisation of many operations. Leske and Hopkins were graduates of the Waite Institute whilst Macleod had been a field officer with plant breeding programmes at the University of Western Australia.

Thus, over the period 1974 to 1980, the breeding team increased from 3 to 6 full time staff with a much wider range of expertise than previously and thus the ability to manage a larger programme with more complex objectives over more sites. Accompanying this development has been an increased collaboration with and reliance on other organisations to provide services and expertise still lacking within the programme, such as the National Rust Control Programme (which was established in 1975) for Stem Rust and Stripe Rust resistance screening and crossing, the continuing services of the Cereal Chemistry Section of the State Department of Services and Supply for advanced quality testing, the State Department of Agriculture for Cereal Cyst Nematode screening and widescale testing of advanced lines, the Waite Agricultural Research Institute for testing and selecting wheats for Eyre Peninsula, and overseas institutions and the Australian Wheat Collection as sources of potential parents.

These developments are summarised by studying the current versus the 1970 breeding method (as shown in Figure 8) the current objectives and the trends in numbers of genotypes under test (Figure 9). Because of the time lag the benefits of this enlarged programme measured as improved varieties being grown by farmers will not be manifest until the late 1980s.

An unfortunate aspect of these developments is that breeders are more answerable to the South Australian taxpayer for new varieties than they are to the College for its educational objectives. This, coupled with an increased complexity and an increased throughput of seed lots in the programme, means that the student is given less time to discuss, contemplate and appreciate what is going on. Automation and mechanisation have worsened this situation. The seeming endlessness to most operations has led to student disenchantment, and they have dubbed Plant Breeding 'Plant Boring'. However, student attitudes and expectations have also changed and the same sad situation might still exist in the 1980s if we were working with the materials and methods of the 1960s.

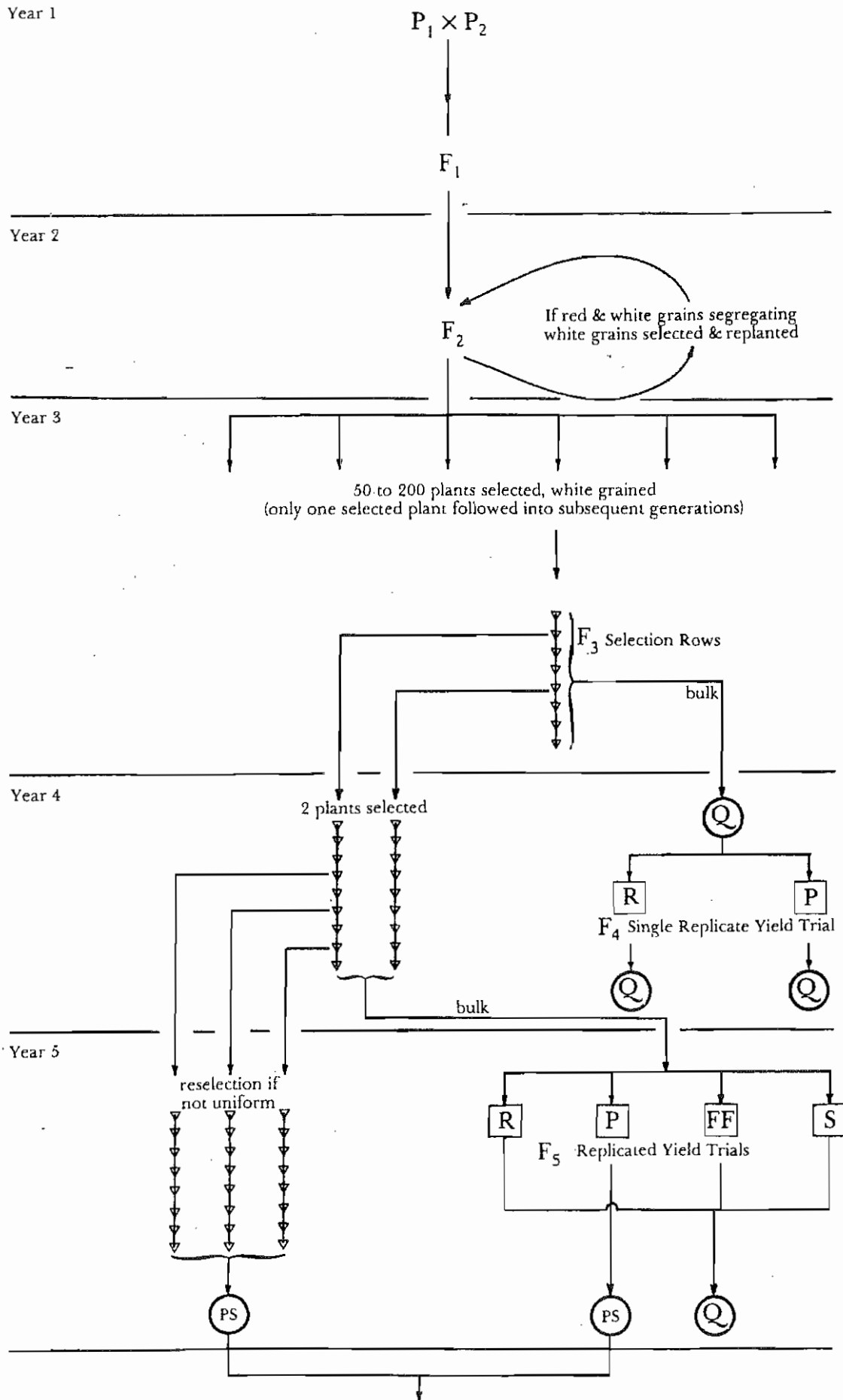
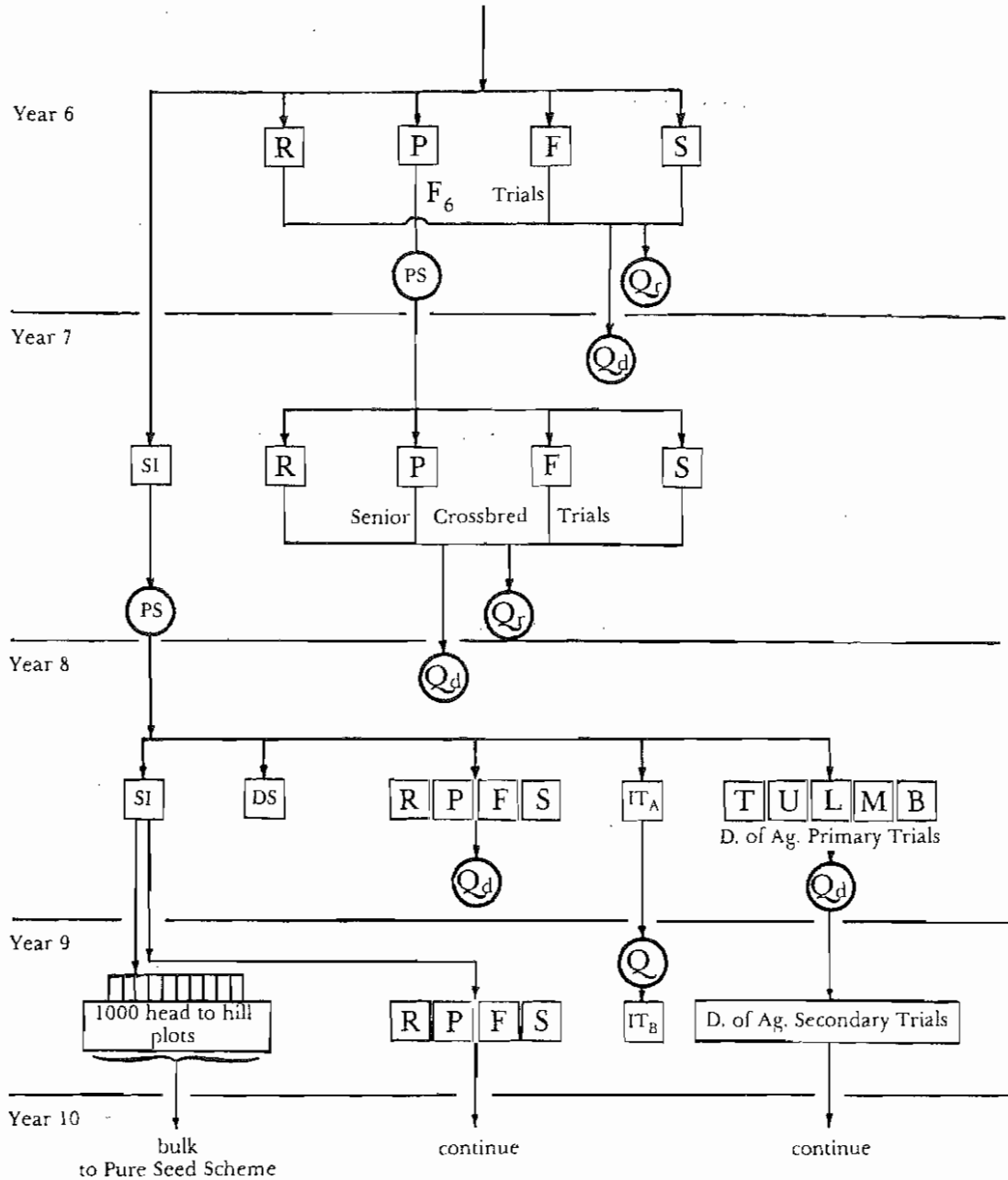

Figure 8: Modified Pedigree System of Wheat Breeding used at Roseworthy College, 1965-1974.



LEGEND

- ▶▶▶▶▶ single plant progeny row
- ⊙ quality tests, by r (Roseworthy) or d (D of Chem)
- growing crop
- R Roseworthy, P Palmer, F Farrell Flat, S Stow
- SI seed increase
- IT Interstate Wheat Variety Trials
- DS disease screen
- ⊙ PS pure seed source

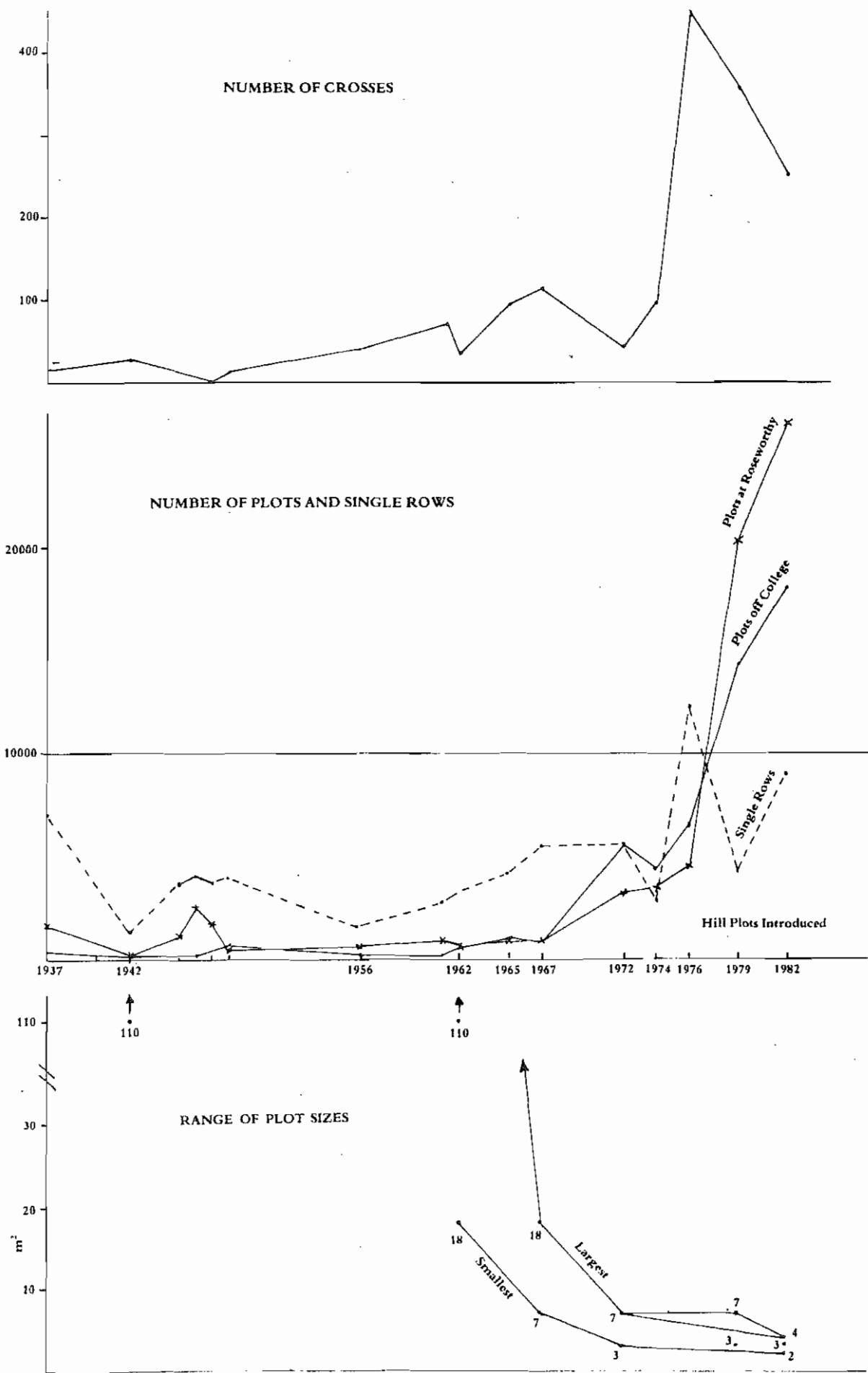

Figure 9. Trends in field activities in wheat breeding at Roseworthy, 1937-1982. (Years are chosen because they are at beginning or end of particular developments)

## *Disease Resistance Breeding at Roseworthy*

Some 42 diseases have been recorded on wheat in South Australia<sup>80</sup> and a far greater number exist within the world, although not yet in South Australia. Since it is not possible for wheat breeders to incorporate resistance to all of these diseases\* into new wheat varieties, some ranking according to their relative economic importance is required. Those rated as causing widespread and greater losses in most years are Cereal Cyst Nematode, Speckled Leaf Blotch and Take-all. Stem Rust and Glume Blotch infrequently cause widespread and greater losses. Other diseases known to farmers such as Common Root Rot, Loose Smut, Blackpoint, Rhizoctonia Bare Patch, Barley Yellow Dwarf Virus, Flag Smut, and Bunt are of lesser importance at this time, although this has not always been the case and in times past Flag Smut and Bunt have been far more important. In the future it will not be the same, for as farming practices change, for example, to stubble conservation and/or minimum tillage techniques those diseases (Rhizoctonia Bare Patch, Speckled Leaf Blotch, Yellow Spot) which carry over on organic matter will become more important. Stripe Rust has also recently been recorded, in 1979, and race changes within specific disease populations will cause some diseases, especially Stem Rust, to flare to prominence and subside in importance in response to climate and wheat variety changes.

### *Flag Smut*

Flag Smut resistance has been a desirable requirement of wheats from Roseworthy since the widespread loss caused by this disease in the 1920s as illustrated by the comment made in the late 1930s regarding the position of Flag Smut in South Australia which '... cannot be considered serious, [but] breeding for resistance to this disease is included in the wheat breeding programme at Roseworthy'.<sup>81</sup> Infection by inoculating seed with spores before seeding was usually successful, and whilst crossbreds were seldom rejected outright if found susceptible, it was taken into account and most lines reaching advanced trials possessed some resistance.

The severity of Flag Smut has declined of recent years, and even those farmers growing susceptible varieties seldom observe the disease. A number of fungicide seed treatments greatly reduce its severity.<sup>80</sup> These facts, coupled with the limitation that using at least one Flag Smut resistant parent in any cross imposes on parent selection, has caused resistance breeding to Flag Smut to be of low priority since the late 1970s.

### *Stem Rust*

Always of high priority in the breeding objectives has been resistance to the prevalent (if not to all current) races of Stem Rust. All past and present wheat breeders at Roseworthy have stated resistance to Stem Rust as one of their objectives. This is no doubt because of the virtual total destruction of susceptible crops over large areas in those seasons when Stem Rust occurs, and because the genetics of resistance is reasonably well understood. However the task is never ending because Stem Rust populations, as well as those of many other diseases, can rapidly evolve by mutation and selection to new more virulent races capable of attacking hitherto resistant varieties.<sup>82</sup> Screening for rust resistance has not been simple in South Australia where the disease is infrequent because normally dry summers followed by dry springs are not conducive to rust epiphytotics. This has meant that new races have usually arisen in areas more prone to summer rain, such as Queensland and northern New South Wales from where they have gradually spread, maybe taking several years to reach South Australia. In this way, although breeders at Roseworthy may have some warning of which races are likely to come, their absence in South Australia has prevented effective screening for resistance.

\*A list of diseases mentioned is included at the end of the references for chapter 3.

Breeding for rust resistance has therefore been effective only for the prevalent races in South Australia at any one time and then only with conscious efforts to create epiphytotics in the breeding nurseries by planting at different times and using irrigation. Effective screening was only possible in occasional years when the propagation process was successful, or when there was a natural outbreak. Breakwell attempted nurseries under irrigation but was frustrated by the failures he had and the smallness of the nursery. A natural infection of his F<sub>2</sub> nursery in 1939 he regarded as opportune because he had made a large number of crosses for Stem Rust resistance at that time, using Eureka and Kenya crossbreds as donors of resistance. He had also used American wheats such as Hope, Marquillo and Webster but found their progeny difficult to select because of red grain, lateness, and tall weak straw.<sup>43</sup> Thus although a highly desirable objective, breeding for Stem Rust resistance has been passive and intermittent, with the chief difficulty encountered by early breeders being the paucity of suitable rust resistant parents. To Roseworthy College came the credit of breeding Ford, the first commercial variety with moderate but effective rust resistance.

Stem Rust caused widespread losses in South Australia in the 1880s, 1901, 1913, 1930, 1932, 1941, 1946, 1947, 1955, 1973 and 1974.<sup>80</sup> These seasons and the couple of years after each outbreak were characterised by a larger than normal number of crosses being made which involved Stem Rust resistant donor parents. The breakdown of each source of resistance can also be followed from the selection programmes. For example, following the 1941 and 1947 outbreaks, Gabo (Sr11) was the main donor whilst after 1955 Festival and Khapstein were extensively used. Following the 1973-74 epiphytotics numerous overseas lines were used as sources of resistance.

A major development in Roseworthy's ability to breed actively for Stem Rust resistance occurred when the National Rust Control Programme was established at the University of Sydney's Plant Breeding Institute, Castle Hill, NSW. This service body, set up after the 1973 and 1974 rust epiphytotics at the instigation of Professor I. A. Watson and financially supported by the Australian Wheat Industry Research Council provides a rust screening service using the most virulent races of the disease available.<sup>83</sup> It also researches and advises on sources of resistance, carries out backcrossing programmes on behalf of wheat breeders in Australia using promising advanced crossbreds, and describes the genotypes of advanced lines with respect to rust genes. Here, at last, was a facility to enable breeders at Roseworthy to attempt to get ahead of the disease and select for resistance to the likely rust races of the future.

#### *Speckled Leaf Blotch*

Speckled Leaf Blotch (*Septoria tritici*) has probably caused damage more often than realised. In 1934, when crops and breeding material were badly infected, none was noted in Ford. Callaghan and Millington suggest that *Septoria*, which is most severe in early plantings in wet seasons, was one reason why earlier maturing varieties were sought so that wheat could be planted later, escape attack, and still yield well.<sup>84</sup> This was not, however, mentioned as an objective in Roseworthy's programme until 1976,<sup>85</sup> since Breakwell dismissed *Septoria* as not of sufficient importance to warrant attention.<sup>81</sup> Changes to more frequent cropping and less tillage have probably increased its importance since that time.

Bad outbreaks in 1974 and 1975 led Wilson to commence studies on this disease and the genetics of resistance. Knowledge in Australia at that time was sparse and unco-ordinated, so with himself as editor he commenced the *Australian Septoria Newsletter* as a means of stimulating interaction between workers on this disease and as a means of co-ordinating an Australian *Septoria* Nursery. Effective sources of resistance and techniques of screening for resistance in field and greenhouse nurseries are now available.<sup>86</sup>

### *Cereal Cyst Nematode*

Roseworthy College farm did not have a serious Cereal Cyst Nematode (CCN) problem until the late 1960s when increased cropping and stocking rates meant a closing of rotations, the cessation of fallowing and the sowing of oats and/or barley into pastures for early winter feed. Thus although CCN had been known in South Australia for a long time and known to cause damage in some areas, Roseworthy did not have resistance as an objective and farmers were left with rotations as the only means of control. In fact when selecting trial sites off-College, known CCN-infested paddocks were avoided. Field infestations of CCN are very patchy and without any known sources of resistance or real manifestations of tolerance to the disease, its occurrence was regarded as a good reason for avoiding the area as a trial site because of the unevenness it caused. Such an infested site occurred at Stow in 1968, and one line, RAC899 (Pinnacle × Sabre), was marked as having much better recovery than others although, being late maturing and of poor quality, it was discarded. Another line, RAC6 (Flameks × Heron) appeared very intolerant. This was the first indication that wheats varied in their tolerance of the disease.

In 1967, P. C. O'Brien, Lecturer in biology at the College, as part of his external studies for a Masters degree at the Waite Agricultural Research Institute, recorded the number of CCN female cysts on 790 wheat varieties in a CCN problem area on the College. Those varieties selected as having less cysts were planted out in 1969 in an infested area at Watchman. Field mouse damage at seeding prevented any yield measurements and so tolerance to CCN could not be assessed, but four wheats (Loros, Spring Wheat, Portugal 131 and Portugal 120) were identified by O'Brien as resistant.<sup>87</sup> Two of these (also discovered independently by workers in Victoria) were used in crosses at Roseworthy but their progeny were discarded from the programme because of poor yield potential before they were satisfactorily screened for CCN resistance. Festiguay, a variety introduced to South Australia in large quantities to combat Stem Rust after 1973 and 1974, fortuitously possessed CCN resistance and considerable tolerance. Thus, by the mid 1970s, several sources of resistance were known although there was no suitable screening technique by which breeders could identify progeny carrying these resistances when they made crosses using these resistant parents. Such techniques now exist<sup>88, 89, 90</sup> and resistance and tolerance to Cereal Cyst Nematode are prime objectives in the breeding programme. Regular tolerance and resistance screening is carried out in carefully chosen field sites and in controlled environments in collaboration with plant pathologists at the State Department of Agriculture.

### *Other Diseases*

The situation with Take-all is now as it was with *Septoria* or CCN about 10 years ago. Breakwell realised the importance of Take-all and associated root rots, describing it and Stem Rust as the 'dreaded diseases'.<sup>81</sup> It is a disease of increasing importance as more frequent cropping is practised. Genetic variation in genotypic response has been known to exist since 1910 or earlier, but the inheritance and mechanism of resistance is unknown. Techniques for screening have now been developed by the CSIRO Division of Soils.<sup>91</sup> Wheat breeders are now on the threshold of making progress in combatting this disease.

The relative importance of other root diseases is still to be established. Until they are, the breeding programme must be flexible enough to review its objectives and breed for resistance to the diseases of most importance. Meanwhile, some protection against unknown root pathogens and other soil disorders (e.g. nutrient deficiencies) can be achieved by testing breeding material through a wide range of environments, soils, climates and farming practices, including tests on some sites especially chosen for disease infestation. The problem of patchiness can be overcome by using techniques of analysis other than the normal analysis of variance. It is thus that is developed in new varieties the property of adapted background, wherein lies their strength and utility.



## *Breeding of Other Crops*

In comparison to what has been given to wheat, the attention given to varietal improvement in other crops at Roseworthy has been scant. Breeding programmes have existed from time to time for barley, oats and peas and in 1948, just after World War II when vegetable oil was scarce, safflower variety trials were conducted.

### *Barley*

Custance included barley and oats in his early variety trials in 1884 when searching for suitable crops for South Australia, and concluded that good malting barley could be grown at Roseworthy. Further trials of local and introduced two- and six-row varieties were started in 1904 but were subsequently considered ambitious in view of the large wheat programme already being undertaken. Work was thus concentrated on single plant selection (such as Spafford's inclination) within six-row Cape types which had been originally introduced from South Africa. Three new varieties—Roseworthy Oregon, Shorthead and Squarehead—were named.<sup>15</sup> Farmers however continued to grow two-row malting types, and six-row feed barleys never became popular.<sup>92</sup>

After these initial variety trials a cross—Shorthead × Squarehead—was made in 1912 but then nothing was done at Roseworthy until Cole made three crosses in 1930 at the suggestion of Barrett Bros., Maltsters. One of these, Prior × Beaven's Special, eventuated in the release of the variety Maltworthy by Breakwell in 1939.<sup>55</sup> Its main attributes were higher yields than the main 2-row variety Prior, drought resistance and good head holding ability, a character which Prior lacked. It was a 2-row type with plump, thin-husked longish grain of the so-called Spratt shape rather than the shorter Chevalier shape of Prior.<sup>93</sup> This difference in grain shape led to a different performance on the malting floor and after extensive floor tests on a commercial scale the trade decided that Maltworthy could not be accepted on equal terms to Prior and thus would only be milling and feed grade. As a result, Maltworthy was never extensively grown.

Barley breeding continued, with crosses in the 1930s aimed at combining the malting quality of two-row barleys with the prolificacy of the six-row types.<sup>33</sup> After World War II Krause again commenced breeding work specifically to improve the yields and straw strength, but above all, the grain-holding ability of Prior which was still the only malting quality barley received. This was attempted by making a series of backcrosses to Prior using Lenta and other donor parents. The last crosses were made in 1958 at which time the work was transferred to the Department of Agriculture and later to the Waite Agricultural Research Institute where more time could be devoted to the crop. Krause continued to see the progeny of his crosses into yield trials. Although nothing came of them several, e.g. BXB3, did show promise.

### *Peas*

The main objective in pea improvement at Roseworthy was to develop a pea which was earlier but no less prolific than White Brunswick and which did not have a tendency to skin and split during harvest.<sup>33</sup> Some plant selection had occurred within White Brunswick but to no avail. Fixed lines from a cross, Early Dun × White Brunswick, were under yield trials in 1937–1939, one of which—of the dark skinned Dun type, and thus not suitable for the split pea trade—was selected as a high yielding, vegetatively vigorous large tough-skinned seeded variety. It was released as Collegian in 1940<sup>43</sup> as the first and, until recently, only Australian bred variety.<sup>94</sup> It is still grown today.

Some 21 crosses were made in 1937 and selections from one cross, Dalby × Lima, were still under test in the early 1950s. No variety was released from these, and no more work has been carried out at Roseworthy in this area.

## Oats

With the exception of work done in the earliest days of the College, little was done in oat improvement until 1925, when crosses were made for three years. A variety known as Champion, reputedly from Roseworthy<sup>107</sup> and probably as a pure line selection was grown in inland districts in the early 1920s. There is no record, however, to suggest that any varieties were released from crossing. It was Breakwell and Callaghan who recommenced oat breeding in the 1930s.

Oats are the most difficult of all cereals to hybridise, which has led to oat breeders often being disappointed by the fruits of their efforts. From the three crosses made in 1933, for example, no grains were produced, and in 1934 of 13 crosses made 6 were unsuccessful with the others averaging 35% seed set. Breakwell persevered because '... all of the existing varieties when grown on the typical limestone soils of the wheat belt of South Australia, appear to be inconsistent and the need for varieties bred and selected *in situ* is rather acute'.<sup>43</sup> He was aiming for a midseason dual-purpose type to give a bulk of early green feed and to recover well after grazing.

Grazing and hay trials were established on both stubble and fallow.<sup>43, 44</sup> Breakwell felt that if farmers paid more attention to the cultivation of oats and chose their varieties carefully Cereal Cyst Nematode would be the only cloud on an otherwise bright horizon for this crop.<sup>95, 96</sup> Although several crossbreds from Early Kherson × Fulghum and Belar × Palestine showed promise, none were released, but they did form the foundation for a more extensive programme after the war, when in 1945 the area devoted to oat improvement in trials was comparable to that devoted to wheat.

This enlarged programme was established by Mertin who approached the problem in a very scientific manner.<sup>97</sup> Before setting his objectives, he conducted a detailed survey to find out the extent of all forms of oat production in South Australia, the requirements of the farmer, the requirements of the miller and the best technical methods for meeting these requirements. He made a comprehensive collection of varieties from various sources and whilst building up seed of them in 1945 assessed each one for its characteristics. The aim of the programme was set down as the production of multipurpose varieties incorporating grazing and recovery potential, strong straw, large grain, disease resistance and reduction of shattering. Crossing was carried out in the field, where Mertin lost most of his first two waves of crosses (1945 and 1946) to gale force winds in both seasons. In 1947 trials were extended to Minnipa and Kybybolite. Krause continued the oat breeding work and intensified the programme in the late 1950s and early 1960s.

The role of oats on farms changed considerably as more and more were sown for grazing only. In 1963 farmers were experimenting with mature, standing oat crops as a form of fodder conservation to be grazed in February and March. The use of oats for hay declined.

Although varieties were being sought for a multitude of uses, the dual purpose types with early vigour, free tillering, good recovery from grazing, strong straw and firmly held grain remained the prime objective. The grain had to be large, cream coloured, awnless and with a thin husk for the export milling trade.<sup>73</sup> Several times, promising oat crossbreds were in seed multiplication plots near release, but were pre-empted by new releases from Western Australia which were similar to the Roseworthy lines. They offered such potential to South Australia that release of the Roseworthy crossbred was withheld. Avon, for example, was released and made the release of OXB12 (Orient × (Victoria × Richland × Boppy)) redundant. OXB48 (OXB12 × Avon) became redundant after Swan was released.

Another very early maturing crossbred, OXB6 (Orient × (Mulgar/Belar)), showed promise for the dry fringes of the cereal belt both as a grazing and grain oat and full registration papers were drawn up under the name Woomera. They were never submitted, since Kent and later Irwin were considered adequate, although considerable

areas of OXB6 were grown in the far west of South Australia in the 1960s after seed somehow escaped from trials. It has never been, however, an officially recognised variety.

Whether the programme was too small to be successful (it was really a sideline to the wheat programme), or whether the objectives were too complex and idealistic to be attainable within the programme, the frustration of never quite producing an improved variety in time caused loss of interest, and crossing work virtually ceased after 1963. A few crosses were made in the years 1968–1970 but selections from these were never yield tested.

Krause, however, never lost enthusiasm for oats as a crop in South Australia and, since leaving the College and studying oat improvement work overseas, he has established a full-sized programme with a full time breeder in the State Department of Agriculture. The collection and breeding material retained at Roseworthy have been passed on to this new programme. At last, hopefully, some serious and permanent breeding can be done with oats in South Australia.

### *Pure Seed Production*

No crop improvement programme is complete without well-organised Pure Seed maintenance, multiplication and distribution, for without a supply of pure seed new varieties will be slow to come into commercial cultivation no matter how good they are. Roseworthy College, with its considerable land resources and agronomic expertise, has been a provider of cereal seed to South Australian farmers since its inception, when this work originally formed part of the duties of the assistant experimentalist, and the farm staff. A large proportion of the College crop was distributed as seed, for example, in the two years 1918 and 1919, when 1,048 bags of wheat, 237 bags of barley, 160 bags of oats, 60 bags of peas and 1 bag of rye were sold as seed. Careful selection of seed for sowing was an important aspect of Spafford's extension work with farmers.

Callaghan implemented a pedigreed seed scheme in 1933 (see Figure 4) to ensure a continuous provision of pure seed, true-to-type, true-to-name and stable in performance.<sup>28</sup> This technique continued with little change until 1975 when it was reviewed in the light of having to maintain seed of newer varieties in which considerable heterogeneity existed. The method was developed around the fact that once seed left the Stud Rows

... certain agencies come into operation which militate against the maintenance of purity. There is constant chance of mechanical mixture, as well as natural crossing between adjacent varieties, or between the variety and any rogue plants which may have intruded as a result of mechanical mixture; further there are factors of genetic instability within the variety itself.

Callaghan did not allow weak quality wheats to be multiplied in this programme so that Roseworthy would not be seen as encouraging the growing of such wheats.<sup>36</sup>

A committee appointed by the Minister of Agriculture to enquire into the problem of improving the milling quality of South Australian wheat proposed in 1936 that the resources of Roseworthy College and Turretfield farm should be used '... to provide select bred seed wheat for distribution'. The seed produced from winning crops at crop competitions also formed a valuable supplement to these supplies.<sup>98</sup>

Roseworthy undertook to grow seed of the State's recommended varieties, after specific variety recommendations were initiated in 1957. As a large number were recommended at any one time, the area sown to each, and thus supplies of each, were limited. To make greater quantities of seed available one of the early projects financed from State Wheat Industry Research Committee was the appointment in 1959 of a pure-seeds officer, initially Peter (Jack) Gratton, RDA, to increase the output of pure seed. This meant an improvement in supervision, control and processing of pure seed. To increase

further the amount of seed available a local farmer (C. K. Oliver, of Wasleys) was contracted to grow the final stages of some varieties<sup>99</sup> for several years from 1961 to 1966.

In seed processing, care has always been taken to control seed-borne diseases. Bunt, controlled originally by use of mercury-based fungicide seed treatments, is now managed by organic systemics. Loose Smut was controlled, until effective systemic seed dressings became available, by hot water treatment of seed prior to seeding the stud plots (Stage III).

As many students of the 1948–1965 period will remember, seed in approximately 25 kg lots contained in loosely-tied jute sacks was soaked in cold water for 5 hours whilst the steam boiler at the Dairy Factory was stoked and given a head of steam. The steam was then used to raise and maintain the temperature of the presoaked seed to 50°C for 95 minutes. This was all carried out in the cheese vats. No doubt former students will also remember that the concrete tennis courts were out of bounds during this treatment, during February–March, because that is where the treated seed was spread to dry.

The amount of seed distributed depended greatly on the amount harvested, the number of varieties being multiplied, and the demand. It could reach up to 200t of commercial seed from as many as 13 varieties (9 wheat and 4 oats) in any one year, with these figures being those for 1964–65. Barley seed was maintained and multiplied at Turretfield Research Centre.

In order further to increase the amount of pure seed available to farmers, especially to enable rapid acceptance of new varieties, the Department of Agriculture in conjunction with Roseworthy set up a registered cereal seed production scheme. Under this scheme, growers were chosen because of their strategic location across the cereal belt and because of their desire to produce seed further to multiply seed supplied from Roseworthy. Roseworthy's seed production role changed to that primarily of providing these registered growers with their requirements from stud plots (now renamed pedigree plots), and secondarily of multiplying seed of those recommended varieties of wheat and oats which were not being grown by the registered growers. Roseworthy itself also acted as a registered grower for the Adelaide Plains area. This made available time and facilities to multiply seed of new or potential varieties should they become recommended varieties for South Australia. This speculative multiplication of seed was often to no end (e.g. Robin in 1968, Cook in 1977, Festiguay in 1979) but, on the other hand, when a variety was recommended, seed was immediately available for the registered growers further to multiply. Halberd, Oxley, Warimba and Bindawarra wheat, and West oats, were in the seed scheme for several years before they were recommended.

Many recent varieties (such as Condor, Warigal and Lance) were not completely uniform when released by their breeder. There are several potential sources of this visual heterogeneity. It can be from residual heterogeneity resulting from modern breeding programmes where single plant selection is minimal and bulking of morphologically similar plants has given seed for the new variety. Alternatively, new heterogeneity can be produced because of high rates of natural outcrossing or chromosome instability, or, thirdly, there can be physical contamination.

It is up to the seed producer and the seed production techniques employed to maintain varieties as close as possible to their genetic constitution when released by the breeder. Purelining a released variety, especially from a limited number of plants such as was being used before 1975, could change the genetic makeup and therefore the performance of heterogeneous varieties. Thus, new procedures have been adopted at Roseworthy which will maintain the genetic integrity of varieties being multiplied (see Figure 10). All stages are carefully rogued\* to remove off-types, and processed, graded

\*The term used to describe the process of removing foreign or rogue varieties from a sample.

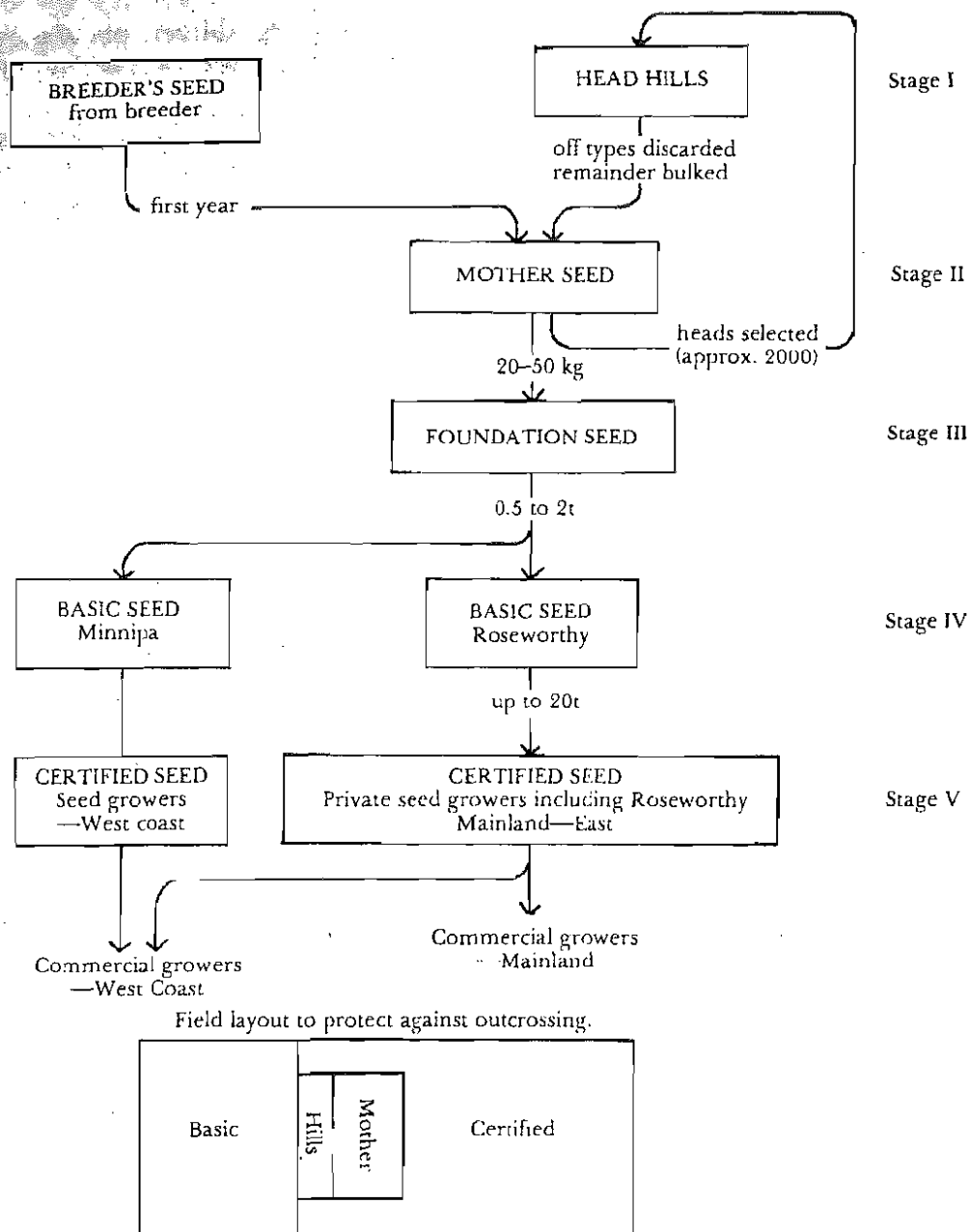

Figure 10: Pure Seed Multiplication Programme, 1975—.

and dressed with a fungicide. Stages 1 to 3, the prebasic generations, are very labour intensive and represent the link between the breeder and commercial seed production. Seed from these is not sold, except for small amounts to Minnipa Research Centre. Roseworthy is the sole supplier of Foundation Seed and, apart from Minnipa, the sole supplier of Basic Seed.

That Roseworthy does this work properly may be taken for granted, but to fail would bring disrepute. The task of staff in this work tends to be less than exciting, but demands extreme attention to detail at all stages of roguing, machinery hygiene, book keeping, seed despatch, and weed control. It also demands a good knowledge of cereal agronomy and seed processing. It is little wonder, then, that the pure seed staff and technical assistants in this work leave for more gratifying occupations. At Roseworthy, pure seeds staff have included Ross Ford, who was pure seeds officer from 1960-62, and who returned in 1963 for another six years after his marriage. He then went to the Rural Development Bank, and was replaced by David Curtis, formerly of Western Australia, who occupied the position from 1969 to 1972 until he returned to university studies in

agricultural economics. Ian Rice, a Roseworthy diplomate, took responsibility for the seed programme after Curtis but eventually transferred to manage the agronomy enterprise of the farm.

Following new breeding research, the lessons learned in the Stem Rust years of 1973 and 1974, when there were the dangers of having too few varieties being grown, and with the maturation of A. J. Rathjen's wheat breeding programme at the Waite Agricultural Research Institute, there has been (and will continue to be) a proliferation of wheat varieties being recommended. Coupled with this has been an even greater number of promising crossbreds from South Australian breeders as well as new releases from interstate, some of which may be destined for recommendation and thus multiplication. To meet this need, a field assistant, Graham C. Hein, was appointed in 1975 to help Rice with an expanded Stages 1 to 3. Hein had previously experienced cereal work but more importantly had been a field supervisor with Alf Hannaford and Co., a commercial seed grading company. Rod A. Jamieson, a New Zealand graduate, took charge of the seed production work in 1978.

An additional responsibility has been the management and data collection in South Australia on a series (usually about 20) of newly released wheat varieties to form a data bank associated with varietal control legislation. These data are collated and published in booklet form.<sup>100, 101</sup>

From the 1981/82 harvest wheat seed has been distributed under a Certified Seed Scheme with the protection and controls that apply to all certified seed. Thus, if anything, the need for prebasic and basic seed has become even more important. The Department of Agriculture is heavily reliant on the provision of wheat seed from Roseworthy. Oats had come under the certified seed scheme several years earlier as a test case but, because of the wild oats and black oats problem on the College farm, there could be no guarantee that oats seed produced on the College could meet Certification standards. Moreover, since oats as a commercial crop had poor gross margins, seed production of oats has not been carried out since 1978.

Whilst no one denies the necessity for a foundation seed wheat programme or the competence of Roseworthy to operate such a programme, its funding has been tenuous. From 1958-1977 it had been supported by the Wheat Industry Research Committee which was forced to withdraw support in 1977 because of lack of funds. Roseworthy was asked to make the programme self supporting, which has been done as far as possible within the limitations of carrying a large number of varieties, some speculative as described above, of selling only 8 to 30t of Basic seed annually, and of setting prices in conjunction with the Department of Agriculture.

There are also internal management and accounting matters at the College which pose some threat to its ability to maintain production of certified seed, one of the ramifications of which was the transfer of Jamieson to another area of the College in 1980. Particularly, the very labour-intensive stages 1 to 3 of the Basic Seed Production programme is costly, but any attempt to recover costs by charging more for Basic seed would penalise and discourage the very farmers, seed-growers and innovators whose valuable work should be encouraged to ensure rapid acceptance of new improved varieties.

A method must be devised to put funding of this work on a permanent basis, with the whole community, which benefits by increased wheat production, providing adequate financial support. The College has much to offer in Basic Seed Production not only but especially in the area of production of seed of older but still recommended varieties, which are no longer financially attractive to private seed producers. The College, however, cannot do it alone.

### *The Past and The Future*

During the last one hundred years profound changes have occurred in the wheat varieties grown in South Australia to give present-day farmers crops which are different

in appearance and behaviour, and much better adapted to their conditions than those of the last century. Some of these changes have been necessary to meet changing farming conditions, for example, changed rotations, changing disease spectra, or to allow wheat to be grown in areas where it had not been grown before. It is not really possible to consider varietal improvement independently of the environment and the management methods by which wheats are grown, since these factors affect the degree to which the potential of a variety is achieved.

Changing agronomic practices (which are discussed elsewhere in this book) aside, C. M. Donald, Emeritus Professor of Agronomy at the Waite Agricultural Research Institute studied the factors affecting wheat production in South Australia for the period 1920–1960, and estimated that about one quarter of the yield increase could be attributed to new varieties,<sup>102</sup> which represents a genetic improvement in yield of 0.6% per annum over the period.

Another analysis of breeders' material and recent releases in South Australia has shown a marked improvement in this rate of progress during the last 20 years, when improved facilities, techniques and exotic germplasm have been used, to a level 2% per annum,<sup>103</sup> although other breeders more concerned about quality and disease resistance may not measure such improvements. Check varieties five years after release are regularly ranked towards the bottom and South Australian crossbreds from Roseworthy and the Waite Agricultural Research Institute top in the Interstate Wheat Variety Trials.\*

That there have been considerable yield increases in varieties is beyond doubt, despite the fact that this is not always apparent in the total wheat harvest because of seasonal factors and trends in farming to more frequent cropping and less inputs per individual crop. With current wheat production, about 1.4 million tonnes annually, and current prices around \$150 per tonne, a yield improvement of 2% is worth \$4.2 million to the farmer and an additional \$6.3 million to the State, totalling over \$10 million annually. That would seem to be fairly telling justification for wheat breeding.

There have been some marked changes in the appearance of wheats as breeding has progressed in South Australia. There has been a trend towards early maturity. There has also been less prolific tiller production and better survival of plants and increased grains per head.<sup>104</sup> By far the most obvious change has been a reduction in height, the recent swing towards semidwarf wheat being a continued expression of this trend.<sup>105</sup> At present most recommended varieties are semidwarf and bearded (awned), although farmers mostly prefer non-bearded wheats.

Because of the dangers of very early varieties having lowered yield potential and being frosted, the trend in earliness has probably gone as far as possible, except in the production of varieties for the dry marginal country where seasons are very short and reseeded is sometimes necessary when wind erosion cuts the initial crop. For dryland farming the trend towards shorter varieties has gone as far as possible. New varieties will be produced which rather than giving wide adaptation will be specifically adapted to problem areas both within and outside the present wheat belt.

Disease resistance in new varieties has always been better than in the varieties which they have replaced, although not always has it been developed in time to combat a disease whose population has also changed to a more virulent race. The breeders' greatest contribution in the future will be to overcome the susceptibility and intolerance of current varieties to diseases, especially root diseases. As more knowledge is gained by plant pathologists, breeders must be ready to put their findings into practice to screen and select for improved varieties. They also must be aware of diseases and pests which are not yet in Australia.

\*The Interstate Wheat Variety Trials, financed by the Wheat Industry Research Council, have been conducted since 1970. The entries in these trials consist of a set of standard varieties against which are compared two or three crossbreds entered by each wheat breeder within Australia. Each trial (set of entries) is grown for two years at up to 15 sites across Australia.

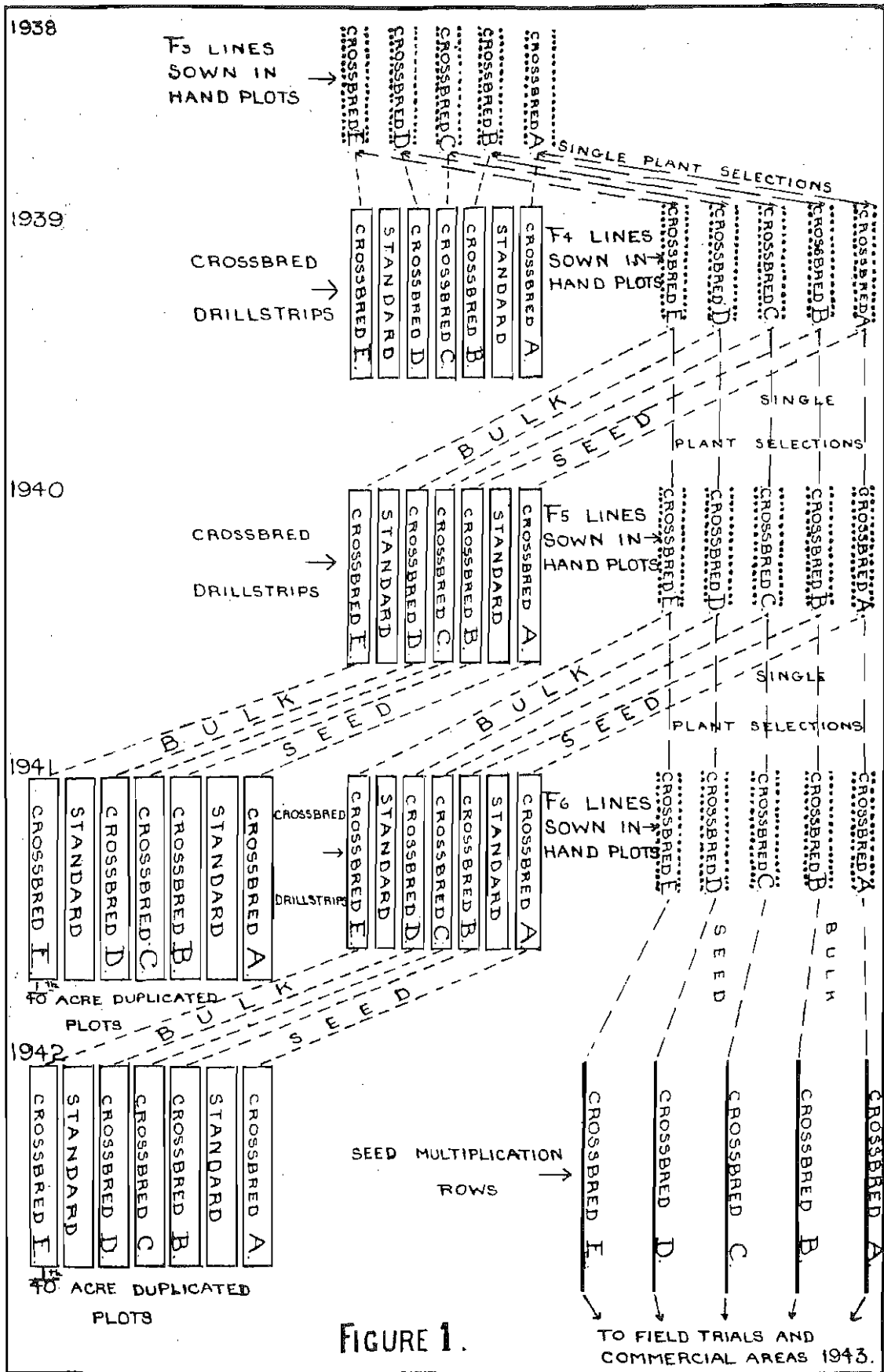

FIGURE 1.

Figure 11: Pedigree Method, Roseworthy 1938. Reproduced from *Journal of Agriculture* February 1939, p. 637.



The quality of the wheat crop has improved with better varieties. Most marked in this area has been an improvement in milling characteristics, flour extraction rates having been increased by several per cent. Wheat varieties exclusively for livestock feed would have very different quality requirements than those currently developed for human consumption.

Breeding methods used at Roseworthy have changed over time. The initial method of pure line selection from heterogeneous varieties was followed by a fairly strict and classical pedigree method (see Figure 11) involving deliberately made crosses using mostly local varieties as parents. Then came the  $F_2$  progeny test method used by Breakwell,<sup>45</sup> which was itself followed by a more extensive use of exotic germplasm using limited single plant selection (see Figure 8).<sup>106</sup> Finally, there is today's method (see Figure 12).

These methods will continue to change and develop as objectives change, as breeders' mechanisation improves and as the needs of the industry dictate. Newer methods of creating genetic variation from which to select will also make contributions. Methods used in genetic engineering and in plant tissue culture could enable the breeder to set objectives and use time scales never thought possible before. Herbicide tolerance, more efficient nutrient use, or nitrogen fixation may well be objectives for the future. Methods such as mutation breeding and the use of male sterility have been investigated but never implemented at Roseworthy. Experiments have been conducted, and are being conducted each year, to investigate ways of improving breeding and selection techniques. The advent of Plant Variety Rights could well change breeding methods to an inflexible system necessary to make varieties distinct, stable and uniform, changes perhaps to methods less efficient in maintaining the rate of progress.

As wheat varieties become more adapted to local conditions it becomes more and more difficult to make further improvements, and hence breeders need to handle more and more material. As objectives become more complex, because of increased knowledge and changed farming practices, more and larger programmes are necessary in order to keep adequate selection pressures on each character. Breeders at Roseworthy have responded to this need, as illustrated, by an analysis of the number of crossbreds and field plots over time (see Figure 9).

Several times the long lag period between making a cross and its coming to fruition as a new variety has been exemplified, showing an average period of about 12 to 15 years. If this is coupled with the lag time after release before the variety makes a significant contribution to the harvest—at least another 5 years—one can see that objectives set and crosses made in 1983 are for the years 2000 and onwards. Any interruption to the programme during this time lag could extend it even further.

One of the attributes ensuring the success of the Roseworthy wheat breeding effort has been its continuity (see Figure 2). The wheat breeders have each been zealous and well trained and have remained at Roseworthy for long enough periods to see material to fruition. When they have left the programme, a successor, often with local knowledge of the breeding material, has been appointed immediately. Competent field staff have maintained the programme in the one or two months in between. Administrators and funding agencies have recognised the needs and problems of breeding, and have encouraged the development of a viable breeding team which at the time of writing could continue almost without interruption should one of them leave. Naturally all the necessary expertise does not exist within the breeding team itself and it must collaborate with others on the College, in other institutions and with farmers\* to obtain services to gather the necessary information for variety selection and release.

\*Collaboration with the University of Sydney, Australian Wheat Collection, Waite Agricultural Research Institute, Departments of Agriculture in South Australia, Western Australia and Victoria and the Department of Services and Supply (Cereal Chemistry Division) of South Australia is essential. The work of these bodies is gratefully acknowledged.

Acknowledged also are the farmers on whose properties trials have been conducted, viz. D. K. Tiller (Stow), C. G. Atkins (Farrell Flat), A. J. Krause (Palmer), P. G. Dunn (Rudall) and A. Glover (Yeelanna).

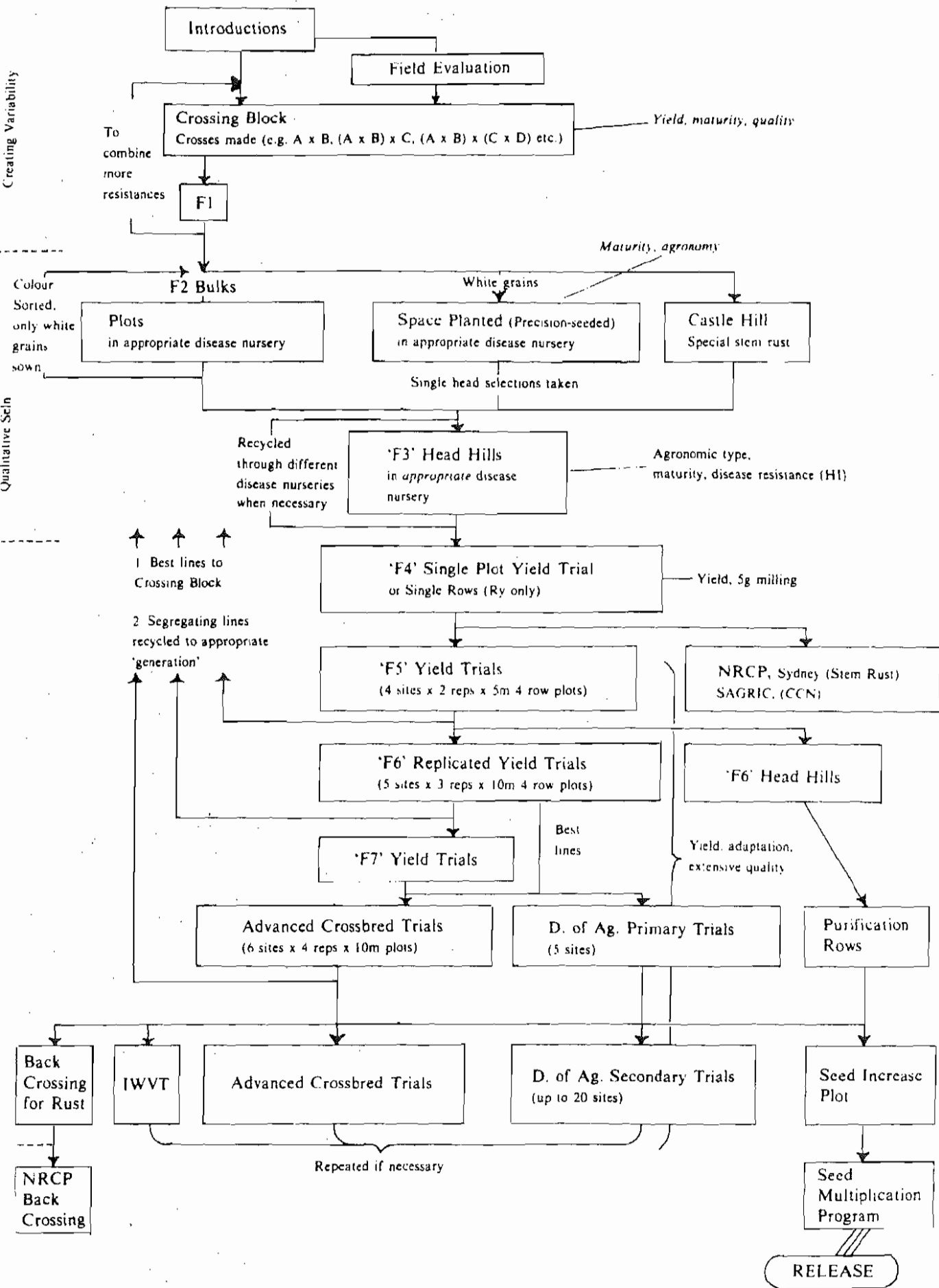
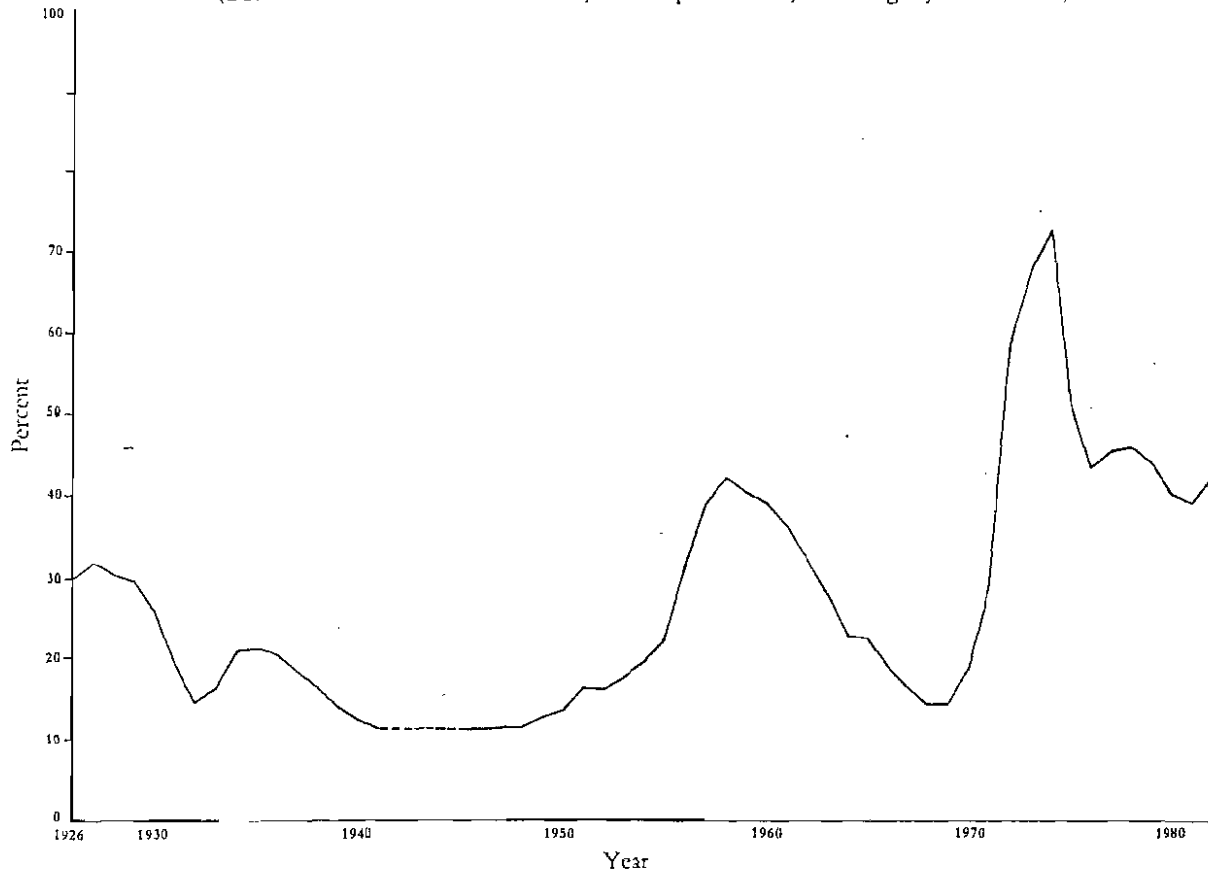

Figure 12: Simplified Flowchart of RAC Breeding Program, 1980.

Figure 13: Proportion of South Australian Wheat Growing Area Sown to Roseworthy College Varieties 1926-82  
(Backcross derivatives of Roseworthy wheats produced by A. T. Pugsley are included)



A large wheat improvement programme also exists at the Waite Agricultural Research Institute under the capable leadership of A. J. Rathjen. Close contact and friendly rivalry exists between the two programmes and the materials and methods used are purposely different even though their objectives are similar, in that both are breeding improved varieties for South Australia. Thus, rather than duplication, there are additional efforts being put into wheat improvement for South Australia than would be possible with only one programme. The two programmes jointly conduct field trials in the more remote areas of the South Australia wheat belt (Eyre Peninsula and the South East) to make as efficient as possible the selection of varieties specifically adapted to those areas.

Wheat is a \$700 million per annum industry in South Australia, which not only provides employment for the state, but generates overseas money as well. Above all, however, it helps to feed an ever-increasing world population, a good part of which is hungry if not starving. As a consequence, continued improvements in yield, quality and disease resistance, brought about in no small part by the skills, patience, devotion, persistence, resilience and sometimes the desperation of plant breeders, are of vital importance for the maintenance of adequate food supplies.

Roseworthy has given (see Figure 13) and must continue to give, due and proper attention to these improvements, which are so necessary not only for South Australia and its wheat industry, but for the world.



W. J. Spafford



R. C. Scott



E. J. Breakwell

Three famous plant breeders who worked at Roseworthy.

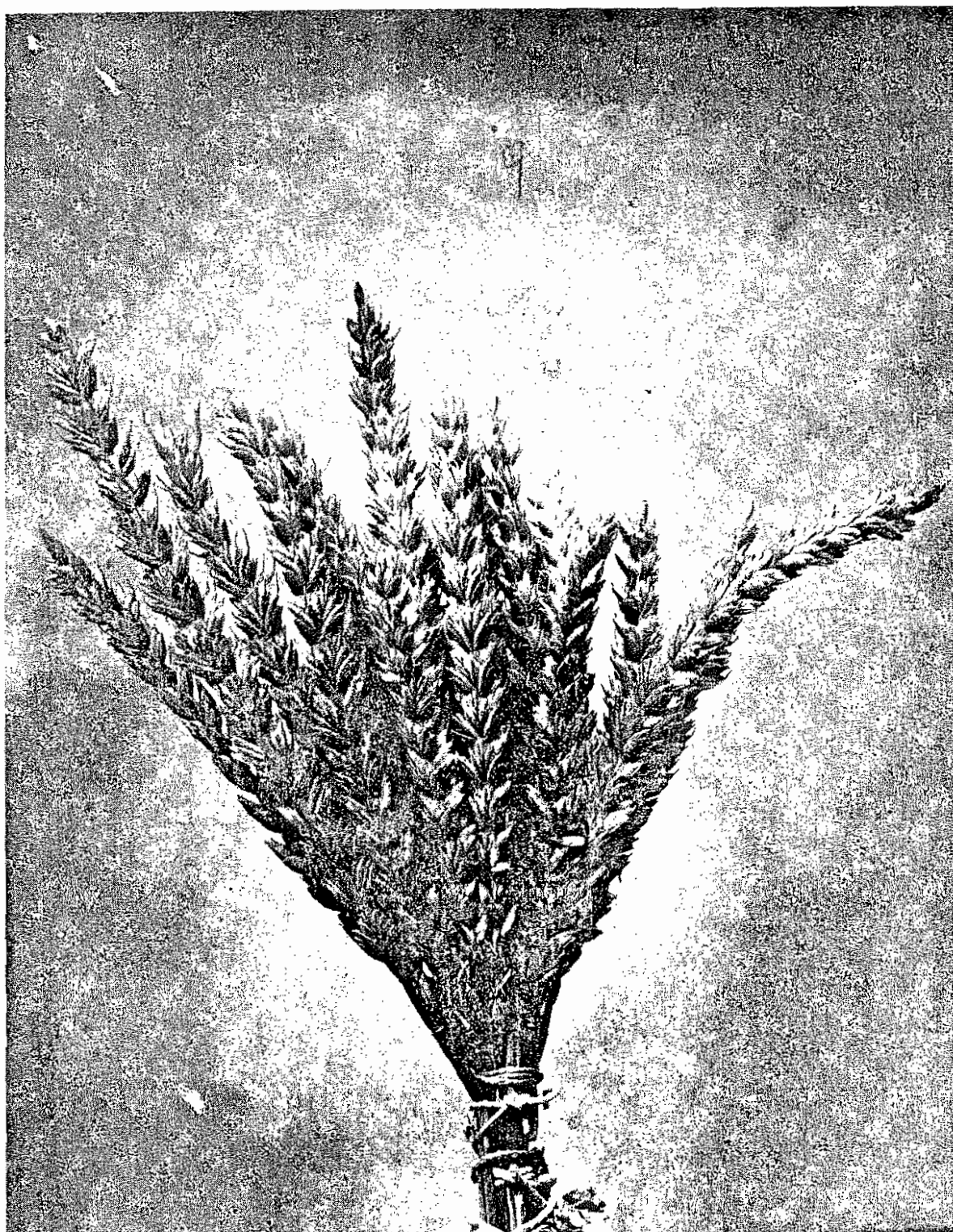

Marshall's No. 3—An early Australian variety first bred 1890.



Typical tall late-maturing wheat, c. 1910.



Rows of variety "Sword", c. 1930.

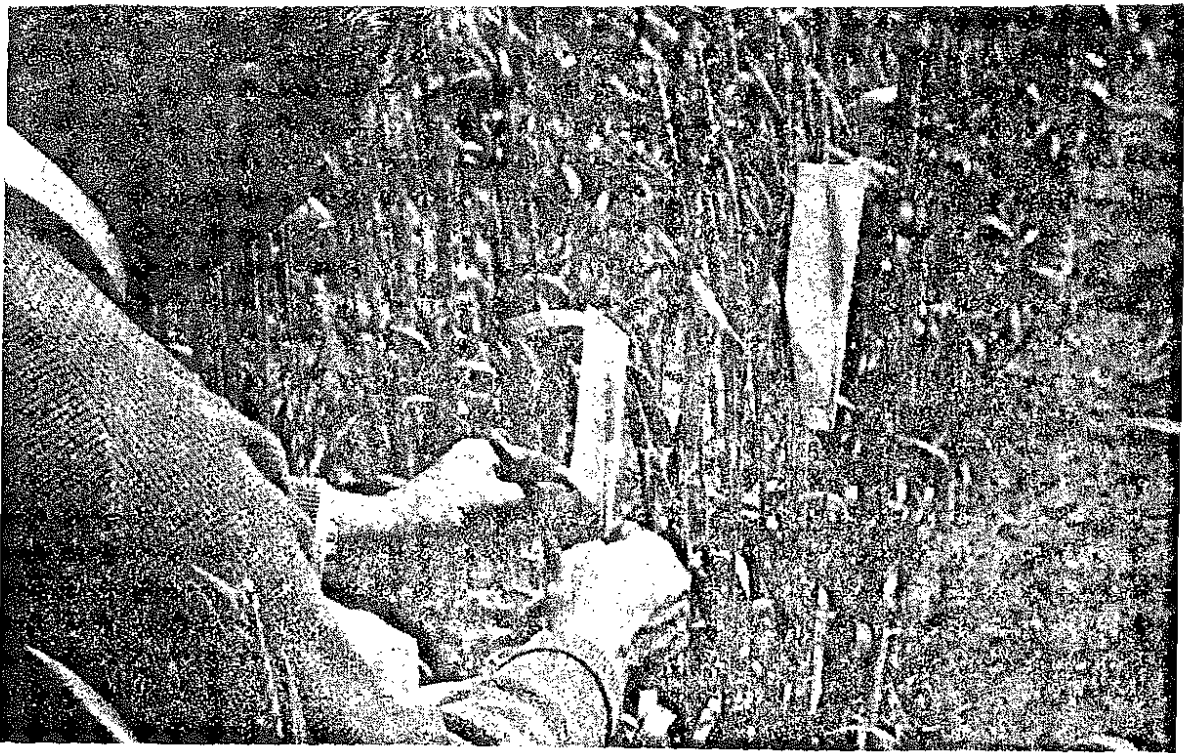

A cereal breeder (M. R. Krause) at work crossing wheat, 1962.



The Roseworthy plant breeding centre, pre-1968.

The new plant breeding centre from 1968.





The rotary cultivator, c. 1940.

Harvesting stud rows, early 1950s.

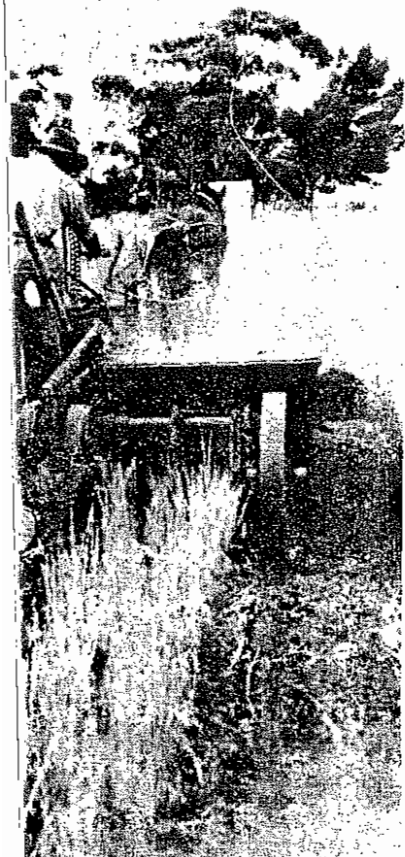

Cleaning the monster, early 1950s.



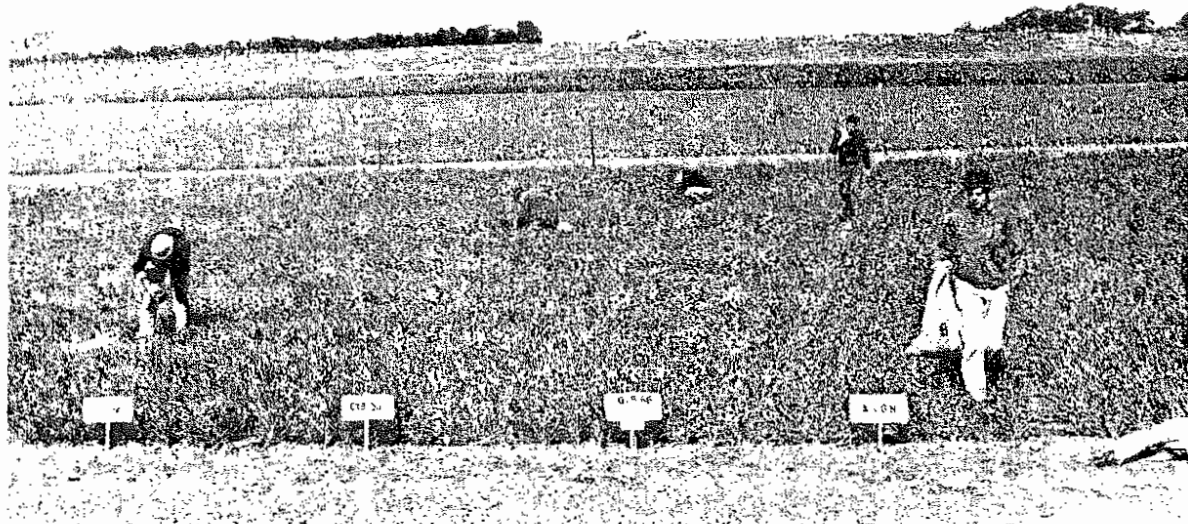

Green forage sampling of oat crossbred grazing varieties, c. 1970.

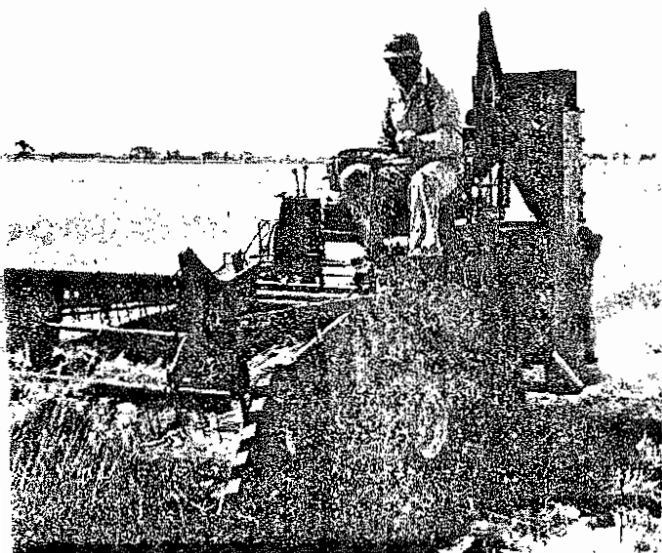

Plant-breeder harvester, 1970s.

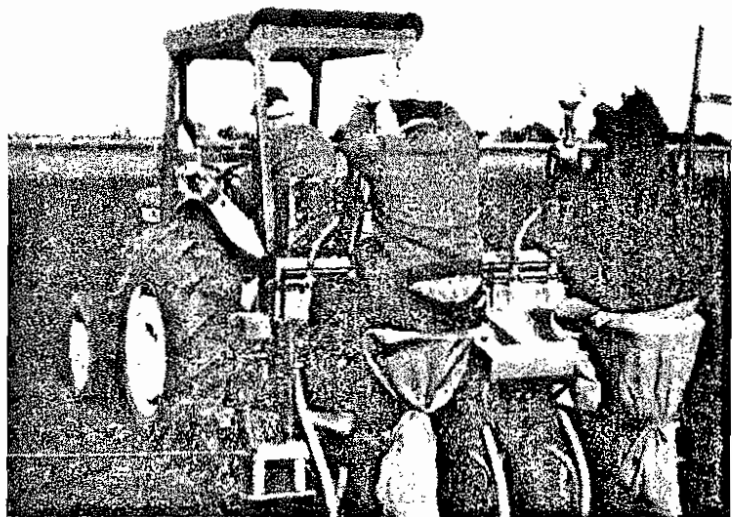

Seeding trials, 1978

Irrigating plots to encourage stem rust for selection for disease resistance, 1980s.

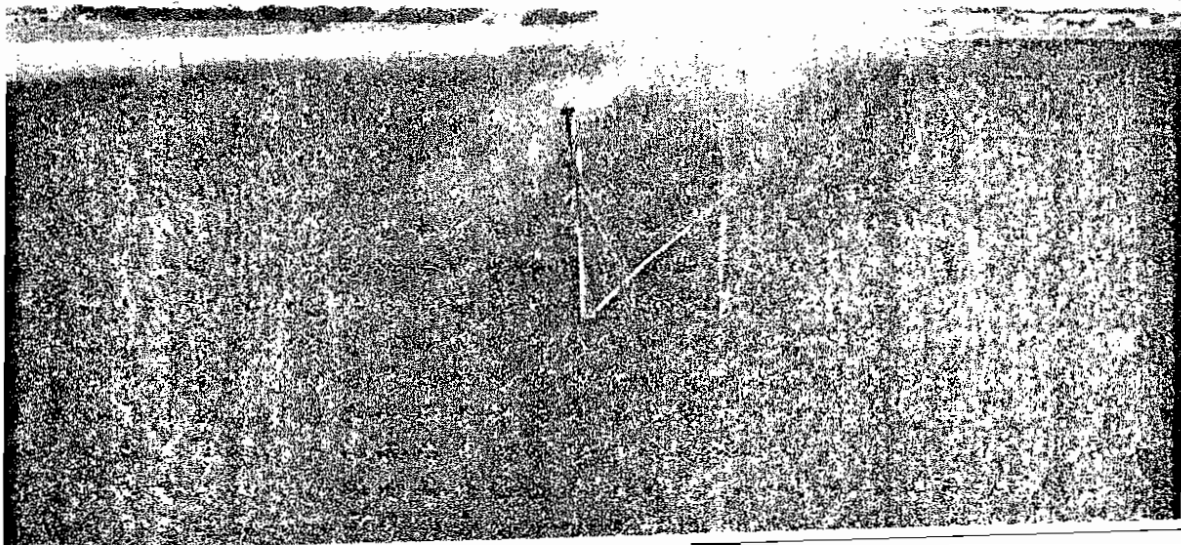

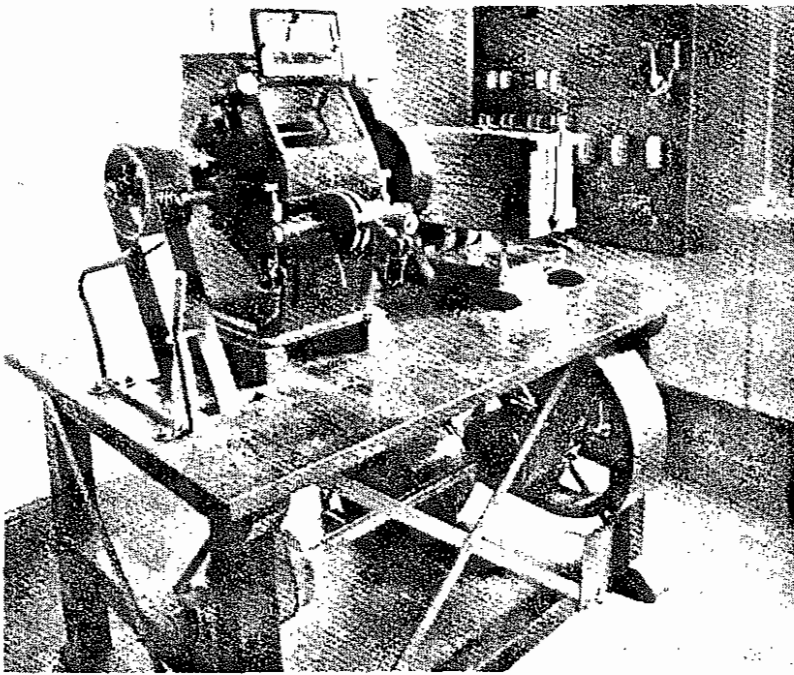

Experimental Flour Mill, 1938.



R. J. Lienert quality testing, 1978.

Senior plant breeder G. J. Hollamby addresses visitors at a Farmers Day, late 1970s. The glasshouses at right enable rapid propagation of wheat generations, and serve a quarantine purpose.



## Chapter 3

1. Custance, J. D., *First Annual Progress Report*, 31 December, 1882, Department of Agriculture, South Australia, 1883.
2. Custance, J. D., *Annual Progress Report*, 31 December, 1883, Department of Agriculture, South Australia, 1884.
3. Dunsdorfs, E. (1956), *The Australian Wheat-Growing Industry 1788-1948*, Melbourne U.P.
4. Scott, R. C. (1932), 'Wheat Varieties in South Australia', *Bull.* 272 Dept of Agriculture, South Australia.
5. *The Garden and Field*, April, 1893: 291-3.
6. 'Wheat Improvement Mr Richard Marshall's Work', *The Garden and Field*, March 1901: 188-190.
7. 'The Improvement of Wheat—Professor Lowrie's Opinions', *The Garden and Field*, April 1901.
8. Marshall, R., 'Improvement of Wheats' *Journal of Agriculture & Industry*, South Australia, December 1901: 475-7.
9. Central Agricultural Bureau report *Journal of Agriculture & Industry*, South Australia, April 1902: 170-1.
10. *The Register*, 8 September 1903.
11. *The Register*, 13 September 1904.
12. Perkins, A. J. (1915), Report of Director of Agriculture. *Report of Minister of Agriculture for year ended 30 June 1914*.
13. Perkins, A. J. (1911), Annual Report of the Roseworthy Agricultural College *Report of Minister of Agriculture of South Australia for year ended 30 June 1911*.
14. Farrer, W. (1898), The Making and Improvement of Wheats for Australian Conditions. *Agricultural Gazette N.S.W.*, 9: 131-168, 241-260.
15. Perkins, A. J. and Spafford, W. J. (1908), 'Improvement of Cereals' Reprint from *Jour. Agric. S.A.*, 31 pp.
16. Macindoe, S. L. and Walkden-Brown, C. (1968), 'Wheat Breeding and Varieties in Australia' *Science Bull.* 76, N.S.W. Department of Agriculture, 255 pp.
17. Spafford, W. J. (1915), 'Wheat Selection' Paper delivered to Agricultural Bureau Conference of Lower Northern Branches. *Jour. Agric. S.A.*, XVIII: 777-783.
18. Spafford, W. J. (1915), 'The Cross-fertilisation of Wheats' *Jour. Agric. S.A.*, 19: 362-375, 628-633.
19. *The Student* XV (1), 1914.
20. *The Student* XVI (2), 1916.
21. R.A.C. Harvest Report 1924-5. *Jour. Agric. S.A.*, 28: 902.
22. R.A.C. Harvest Report 1930-1, *Jour. Agric. S.A.*, 34: 758.
23. *The Student* XXIII (1) 1924.
24. *The Advertiser*, November 29, 1950.
25. *The Student* December 21, 1932.
26. Hayes, H. K. and Garber, R. J. (1927), *Breeding Crop Plants*, ed. 2, McGraw Hill, N.Y.
27. Fisher, R. A. (1925), *Statistical Methods for Research Workers*, Oliver & Boyd, Edinburgh.
28. Callaghan, A. R. (1933), 'An outline of work in progress, or contemplated, at Roseworthy Agricultural College, additional to activities connected with the training of students' *Jour. Agric. S.A.*, 36: 1344-1349.

29. Callaghan, A. R., Breakwell, E. J. and S. R. Klose (1934), 'Activities of Roseworthy Agricultural College 1933-34. III Cereal breeding, pure seed production and variety trials' *Jour. Agric. S.A.*, 38: 12-23.
30. Callaghan, A. R.; Breakwell, E. J. (1936), 'Activities of Roseworthy Agricultural College 1934-35. III Progress in the improvement of the baking quality of South Australian wheat' *Jour. Agric. S.A.*, 39: 1112-1123.
31. Chapman, C. E. and Farquar, A. J. (1934), 'Quality of South Australian Wheats' *Jour. Agric. S.A.*, 38: 40-53.
32. Hickinbotham, A. R. (1934), 'The Baking Qualities of Australian Wheats' *Jour. Agric. S.A.*, 38: 190-200.
33. Callaghan A. J. and Breakwell, E. J. (1936), 'Activities of Roseworthy Agricultural College 1935-36. IV Cereal Breeding and Experimental Work' *Jour. Agric. S.A.*, 40: 111-121.
34. *The Student XXXI* December, 1935.
35. *The News*, January 7, 1935.
36. *The Chronicle*, January 10, 1935; October 10, 1935; October 17, 1935; October 24, 1935.
37. *Kapunda Herald*, April 5, 1935.
38. *The Farm*, June 1, 1935.
39. Callaghan, A. J., Breakwell, E. J. and Klose, S. R. (1936), 'Activities of Roseworthy Agricultural College 1934-35. IV Cereal Breeding Experiments and Pure Seed Production' *Jour. Agric. S.A.*, 39: 891-901.
40. *The Student XXXII*, December 21, 1936.
41. *The Student XXXIII*, December 21, 1937.
42. *The Student XXXIV*, December 1938.
43. Breakwell, E. J. and Mellor, D. H. S. (1940), 'Plant Breeding and Some Experimental Work at Roseworthy College, 1939-40' *Jour. Agric. S.A.*, 44: 252-259.
44. Breakwell, E. J., Hutton, E. M. and Mellor D. H. S. (1940), 'Cereal Breeding and Variety Trials at Roseworthy College, 1938-39' *Jour. Agric. S.A.*, 43: 524-533.
45. Breakwell, E. J. and Hutton, E. M. (1939), 'Cereal Breeding and Variety Trials at Roseworthy College, 1937-38' *Jour. Agric. S.A.*, 42: 632-645.
46. Hutton, E. M. (1937), 'Wheat as Foodstuff' *Jour. Agric. S.A.*, 40: 944-945.
47. Hutton, E. M. (1938), 'Wheat as Food' *Jour. Agric. S.A.*, 42: 338-340.
48. Hutton, E. M. (1939), 'Quality in Wheat' *Jour. Agric. S.A.* 42: 965-967.
49. Breakwell, E. J. and Hutton, E. M. (1938), 'Studies on the effect of weathering on the commercial value of wheat samples from the 1937-8 Harvest' *Jour. Agric. S.A.*, 41: 777-790.
50. Breakwell, E. J. and Hutton, E. M. (1939), 'South Australian Grain Studies. I Variation in protein content and diastatic activity throughout the wheat belt of South Australia' *Jour. Agric. S.A.*, 42: 683-697.
51. Breakwell, E. J. and Hutton, E. M. (1939), 'South Australian Grain Studies. II Some Practical implications of the variation in protein content and diastatic activity of grain from the South Australian Wheat Belt' *Jour. Agric. S.A.*, 42: 767-780.
52. Hutton, E. M. (1942), 'The Gassing Ability of South Australian Flour' *Jour. Agric. S.A.*, 44: 320-324.
53. Callaghan, A. R. (1940), 'Roseworthy Agricultural College. New Varieties of Wheat, Barley and Field Pea' *Jour. Agric. S.A.*, 43: 534.
54. *The Student XXXIV*, December 1938.
55. *The Student XXXV*, December 1939.
56. *The Student XXXVI*, December 1940.
57. Rathjen, A. J. and Pugsley, A. T. (1978), 'Wheat Breeding at the Waite Institute, 1925-1978' *Biennial Report of the Waite Agricultural Research Institute*, Adelaide: 12-37, 1976-77.
58. Anon (1949), 'Baking Quality of Wheat Varieties. Dirk 48 Recommended by Wheat Improvement Committee' *Jour. Agric. S.A.*, 52: 435.
59. *The Student XL*, December 1944.
60. *The Student XLI*, December 1945.
61. *The Student XLII*, December 1946.
62. Callaghan, A. R. (1954), 'Quality in the Australian Wheat Crop—The 1954 Farrer Memorial Oration' *Jour. Agric. S.A.*, 58: 3-10.
63. *The Student XLIV*, December 1948.
64. Cook, L. J. (1949), 'Results of Replicated trials with wheat varieties 1948-49' *Jour. Agric. S.A.*, 52: 407-410.
65. Walker, A. J. K. (1953), 'Results of Wheat Variety Trials in South Australia' *Jour. Agric. S.A.*, 56: 479-492.
66. Pearson, F. B. (1957) 'Choosing Wheat Varieties' *Jour. Agric. S.A.*, 60: 333-488.
67. Johnson, J. A., Shellenberger, J. A. and Swanson, C. O. (1946), 'Farinograms and Mixograms as a means of evaluating flours for specific uses' *Cereal Chemistry* 23: 388-399.
68. Callaghan, A. R. (1957), 'Classing and Grading Wheat' *Jour. Agric. S.A.*, 61: 219-229.
69. Anon (1961), 'Best wheat varieties—District Recommendations' *Jour. Agric. S.A.*, 65: 49-53.
70. Heard, T. G. (1962), 'The zone plan for 1963 wheat sowings' *Jour. Agric. S.A.*, 66: 178-181.
71. *The Student LVI*, 1950.
72. *The Student LVII*, 1961.
73. Krause, M. R. (1963), '50 Years of Cereal Improvement at Roseworthy' *The Student LVIII*, 6-14.
74. Krause, M. R. (1966), 'A Comparative study of wheat selection with Divergent Length from Separate Origins', M.Sc. (Agronomy), Thesis, U. of Washington.
75. Anon (1979), 'Top Wheat Varieties' *Wheat Australia* 12 (4): 4.
76. Udy, D. C. (1956), 'Estimation of protein in Wheat and Flour by ion binding' *Cereal Chemistry* 33: 190-197.
77. Pinckney, A. J., Greenaway, W. T. and Zeleny, L. (1957), 'Further developments in the sedimentation test for Wheat Quality' *Cereal Chem.* 34: 16-25.
78. Hollamby, G. J. (1973), 'The Measurement of Genotype—Environment Interaction in Plant Breeding', M.Ag.Sc. Thesis, U. of Adelaide.
79. Richardson, J. H. (Chairman) (1981), Field Crop Improvement Review. Report to Research Policy Advisory Committee of the South Australian Department of Agriculture, Mimeo, 33 pp.

80. Mayfield, Allen H. (1981), 'Economic Importance of Diseases of wheat in South Australia' *Plant Industry Division Report* No. 1, 1981, Dept. of Agric., South Australia. Mimeo, 58 pp.
81. Breakwell, E. J. and Hutton, E. M. (1938), 'Cereal Breeding and Variety Trials at Roseworthy College, 1936-37' *Jour. Agric. S.A.*, 41: 551-564.
82. Heard, T. G. (1960), 'Stem Rust of Wheat. Progress towards complete resistance' *Jour. Agric. S.A.*, 64: 134-135, 140.
83. Anon (1975), 'National Wheat Rust Control Program is Launched' *Wheat Research* 1 (1): 2-3.
84. Callaghan, A. R. and Millington, A. J. (1956), *The Wheat Industry of Australia* Angus and Robertson, Sydney.
85. Wilson, R. E., Hollamby, G. J., Dube, A., Simon, A. and Hardy, P. (1977), 'Identification and Control of Wheat Diseases'. Farmer Workshop, Roseworthy Agricultural College, October 1977. Mimeo, 36 pp.
86. Wilson, R. E. (1979), 'Resistance to *Septoria tritici* in two wheat cultivars determined by independent, single dominant genes' *Australian Plant Pathology* 8 (2): 16-19.
87. O'Brien, P. C. and Fisher, H. M. (1974), 'Resistance within wheat barley and oat cultivars, to *Heterodera avenae* in South Australia' *Aus. Jour. expl. Agric. and An. Husb.* 14: 399-404.
88. O'Brien, P. C. and Fisher, H. M. (1977), 'Development of *Heterodera avenae* on resistant wheat and barley cultivars' *Nematologica* 23: 390-397.
89. Fisher, H. M., Rathjen, A. J. and Dube, A. J. (1981), 'Tolerance of Commercial Cultivars and Breeders' Lines of wheat to *Heterodera avenae*, Woll'. *Aust. J. Agric. Res.* 32: 545-51.
90. Wilson, R. E., Hollamby, G. J. and Bayraktar, A. (1982), 'Field selection for Cereal Cyst Nematode Tolerance and Resistance' *Australian Field Crops Newsletter* 17: 22-23.
91. Kovira, A. D. (1982), Soils Division, CSIRO, Glen Osmond, South Australia, Personal communication.
92. Sparrow, D. H. B. and Doolette, J. B. (1975), 'Barley' *Australian Field Crops, I Wheat and other temperate cereals* edited by A. Lazenby and E. M. Matheson, Angus and Robertson.
93. Breakwell, E. J. and Mellor, D. H. S. (1941), 'Plant Breeding and Experimental Work at Roseworthy College 1940-41' *Jour. Agric. S.A.*, 45: 288-293.
94. *The Student* XLIII, 1947.
95. Breakwell, E. J. (1939), 'Oats and Oaten Varieties' *Jour. Agric. S.A.*, 43: 310-313.
96. Breakwell, E. J. (1945), 'Some Post-war Problems for the Plant-Breeder' *Jour. Agric. S.A.*, 48: 385-387.
97. Mertin, J. V. (1948), 'Oat Improvement in South Australia' *Jour. Agric. S.A.*, 51: 532-537.
98. *The Advertiser*, May 3, 1936.
99. Krause, M. R. (1959), 'Pure Seed Production' *The Australasian Plant Breeding and Genetics Newsletter* 14: 3.
100. Ferns, G. K., Fitzsimmons, R. W., Martin, R. H., Simmonds, D. H. and Wrigley, C. W. (1975), *Australian Wheat Varieties—Identification according to growth, head and grain characters* CSIRO.
101. Ferns, G. K., Fitzsimmons, R. W., Martin, R. H. and Wrigley, C. W. (1978), *Australian Wheat Varieties—Supplement No. 1* CSIRO.
102. Donald, C. M. (1965), 'The progress of Australian Agriculture and the role of pastures in environmental change' *Aust. J. Sci.* 27: 187-197.
103. Pederson, D. G. and Rathjen, A. J. (1981), 'Choosing Trial Sites to maximize selection response to grain yield in spring wheat' *Aust. J. Agric. Res.* 32: 411-424.
104. Lawrence, G. J. (1968), 'A comparative study of old and new cultivars of wheat and barley' Student project, Waite Agricultural Research Institute, University of Adelaide, Glen Osmond, South Australia.
105. Syme, J. R. and Thompson, J. P. (1977), 'Morphological Attributes of Australian and Mexican Wheat cultivars' *Proceedings 3rd Intl. Congress of SABRAO*, Canberra, February 1977: 5 (c), 19-22.
106. Hollamby, G. J. (1975), 'Wheat breeding goals and programme at Roseworthy Agricultural College, South Australia' Mimeo. 26 pp.
107. Archer, Ellmor (1922), A classification and detailed description of the Oats of Australia' *Bull.* 23 CSIR, 31 pp.

## Scientific Names of Wheat Diseases Mentioned in Text

Cereal Cyst Nematode (*Heterodera avenae* Woll.)  
 Speckled Leaf Blotch (*Septoria tritici* Roberge ex Desm.)  
 Take-all (*Gaeumannomyces graminis* (Sacc.), Arx & Oliver var. *tritici* Walker)  
 Stem Rust (*Puccinia graminis* Pers. f. sp. *tritici* Eriks & Henn)  
 Glume Blotch (*Septoria nodorum* (Berk.), Berk)  
 Common Root Rot (*Helminthosporium sativum* Parmel, King & Bakke)  
 Loose Smut (*Ustilago tritici* (Pers.), Rostrup)  
 Black point (*Alternaria alternata* (Fr.), Keissler)  
 Rhizoctonia Bare Patch (*Rhizoctonia solani* Kuhn)  
 Flag Smut (*Urocystis agropyri* (Preuss.), Schroet.)  
 Bunt (*Tilletia caries* (DC), Tul.), and (*T. foetida* (Wallr.), Liro)  
 Yellow Spot (*Pyrenophora tritici-repentis* (Died.), Drechsler)  
 Stripe Rust (*Puccinia striiformis* Westend. var. *striiformis*)

