

# SEA Gas Project

Naracoorte  
Lateral Pipeline

Pipeline Licence Extension



Environmental  
Impact  
Report

SOUTH EAST AUSTRALIA



August 2004

# Naracoorte Lateral Pipeline

## Pipeline Licence Extension

# Environmental Impact Report

**August 2004**



**South East Australia Gas Pty Ltd**  
(A.C.N. 096 437 900)

Level 4, 70 Hindmarsh Square  
Adelaide, South Australia 5000

Telephone: 08 8236 6800

Facsimile: 08 8236 6899

Email: [seagas@seagas.com.au](mailto:seagas@seagas.com.au)

## Prepared for:

GPA Engineering  
91 Magill Road  
STEPNEY  
South Australia 5069

## On behalf of:

South East Australia Gas Pty Ltd  
ACN 096 437 900  
Level 4, 70 Hindmarsh Square  
ADELAIDE  
South Australia 5000

## Prepared by:

Ecos Consulting (Aust) Pty Ltd  
ABN 57 081 918 194  
26 Greenhill Road  
WAYVILLE  
South Australia 5034

ph: (08) 8357 0400  
fax: (08) 8357 0411  
ecos@ecos.com.au  
www.ecos.com.au



© 2004 Ecos Consulting (Aust) Pty Ltd,  
ABN 57 081 918 194

All rights reserved. No part of this document covered by copyright may be reproduced or copied in any form including photocopying, recording or information retrieval systems, without our written permission.

DOCUMENT CONTROL SHEET						
Sea Gas Project - Environmental Impact Report for Naracoorte Lateral Pipeline						
ENV 571						
Document Reference	Revision Number	Revision Date	Compiled by	Checked by	Approved by	Comment
571-Naracoorte Lateral-EIR	A	6-Aug-04	ZB, SM	SM	SM	Issued for review
	0	23-Aug-04	ZB,SM	SM	SM	Issued to client

## Contents

<b>Executive Summary</b> .....	<b>iv</b>
<b>1 Introduction</b> .....	<b>1</b>
1.1 Background.....	1
1.2 Project Proponent.....	1
1.3 Environmental Commitment.....	1
1.4 Regulatory Framework.....	2
1.4.1 Environmental Impact Report.....	2
1.4.2 Statement of Environmental Objectives.....	2
1.4.3 Other Legislation and Approvals.....	2
1.5 About This Document.....	3
<b>2 Project Description</b> .....	<b>5</b>
2.1 Project Overview.....	5
2.2 Project Schedule.....	5
2.3 Design and Engineering.....	5
2.4 Construction.....	6
2.5 Operation.....	8
2.6 Decommissioning.....	8
2.7 Project Rationale and Alternatives.....	8
2.7.1 Pipeline Corridor Alternatives.....	8
<b>3 Management of Environmental Issues</b> .....	<b>9</b>
3.1 SEA Gas Environmental Management Strategy.....	9
3.2 Climate.....	9
3.3 Soils and Terrain.....	9
3.3.1 Existing Environment.....	9
3.3.2 Potential Impacts.....	10
3.3.3 Impact Mitigation.....	10
3.4 Hydrology.....	10
3.4.1 Existing Environment.....	10
3.4.2 Potential Impacts.....	11
3.4.3 Impact Mitigation.....	11
3.5 Noise Emissions.....	12
3.5.1 Existing Environment.....	12
3.5.2 Potential Impacts.....	12
3.5.3 Mitigation Measures.....	14
3.6 Atmospheric Emissions.....	14
3.6.1 Existing Environment.....	14
3.6.2 Potential Impacts.....	14
3.6.3 Mitigation Measures.....	14
3.7 Flora and Fauna.....	15
3.7.1 Existing Environment.....	15

3.7.2	Potential Impacts .....	17
3.7.3	Impact Mitigation.....	17
3.8	Cultural Heritage .....	18
3.8.1	Existing Environment .....	18
3.8.2	Potential Impacts .....	18
3.8.3	Impact Mitigation.....	18
3.9	Land Use .....	19
3.9.1	Existing Environment .....	19
3.9.2	Potential Impacts .....	19
3.9.3	Impact Mitigation.....	19
3.10	Public Risk and Safety .....	19
3.10.1	Existing Environment .....	19
3.10.2	Potential Impacts .....	20
3.10.3	Mitigation Measures.....	20
3.11	Hazardous Storage, Spill and Emergency Response .....	20
3.12	Additional Mitigation Strategies .....	21
3.12.1	Construction Environmental Management Plan .....	21
3.12.2	Awareness Program.....	21
3.12.3	Contractual Obligations .....	21
<b>4</b>	<b>Consultation .....</b>	<b>22</b>
4.1	Key Stakeholders.....	22
4.1.1	Landowners/occupiers.....	22
<b>5</b>	<b>Statement of Environmental Objectives .....</b>	<b>24</b>
<b>6</b>	<b>Conclusion.....</b>	<b>26</b>
<b>7</b>	<b>References.....</b>	<b>27</b>
<b>8</b>	<b>Abbreviations.....</b>	<b>28</b>

## List of Tables

Table 1: Pipeline Engineering and Design Features.....	5
Table 2: Pipeline Construction Sequence .....	6
Table 3: Predicted Maximum Pressure Safety Valve Noise – dB(A) .....	13
Table 4: Plant Species Recorded on the Easement .....	16
Table 5: Stakeholder Consultation.....	22
Table 6: Landholders on the Naracoorte Lateral Pipeline.....	23
Table 7: Relevant Objectives from the SEA Gas Project SEO (November 2002).....	24

## List of Figures

Figure 1: Proposed Naracoorte Lateral Pipeline Alignment .....	4
Figure 2: Typical Layout of Construction Right-of-Way for a Small-Bore Pipeline.....	7

## List of Plates

Plate 1: Small Drain Across Easement (Facing South Across Easement).....	11
Plate 2: Pipeline Alignment Showing Large Red Gums on Easement .....	15
Plate 3: Proposed Meter Station Site .....	16

# Executive Summary

The joint venture company South East Australia Gas Pty Ltd (SEA Gas) plans to construct a lateral pipeline to supply natural gas to a customer at Naracoorte. The pipeline, referred to as the 'Naracoorte Lateral', will be 1.5km long and will start at an off-take valve on the SEA Gas Pipeline (at Kilometre Point 286.3). The Naracoorte Lateral will terminate at the Teys Bros Abattoir, approximately 8km east of Naracoorte.

SEA Gas currently owns and operates the SEA Gas Pipeline under Pipeline Licence 13 (PL13). It is proposed that the Naracoorte Lateral pipeline be authorised as an extension to PL13.

The SEA Gas Project Environment Effects Report / Environmental Impact Report (SEA Gas Project EER/EIR) describes the general environmental impacts of the construction and operation of the main pipeline however it does not cover additional lateral pipelines. This document has been prepared to cover this lateral pipeline.

This document summarises, in conjunction with the SEA Gas EER/EIR (October 2001), the environmental hazards associated with the construction and operation of the proposed lateral pipeline.

The pipeline is aligned in cleared farming land and there is no major potential impacts identified. This document identifies the following as the main potential impacts:

- compaction or inversion of soils
- introduction of agricultural weeds
- noise emissions from operation of pressure safety valves
- disturbance to nesting Red-Tailed Black Cockatoos (if present).

This EIR outlines general mitigation strategies that address these potential impacts. Detailed task-specific management and mitigation requirements will be included in the Construction Environmental Management Plan.

The Naracoorte Lateral pipeline involves the construction of infrastructure in a degraded environment of low population density. The pipeline does not impact on environmentally and culturally sensitive areas. The potential impacts to landholders, the environment and stakeholders are expected to be short-term and minor in extent. No significant long-term adverse impacts are expected.

The existing SEA Gas Project Statement of Environmental Objectives (November 2002) adequately covers the objectives and assessment criteria associated with this extension to the SEA Gas pipeline licence and has not been revised.

# 1 Introduction

## 1.1 Background

The joint venture company South East Australia Gas Pty Ltd (SEA Gas) plans to construct a lateral pipeline to supply natural gas to the Teys Bros Abattoir near Naracoorte. This pipeline, referred to as the 'Naracoorte Lateral', will be 1.5 km long. The Naracoorte Lateral will commence at the Naracoorte off-take valve on the SEA Gas Pipeline (KP286.3) and terminate at the Teys Bros Abattoir, approximately 8 km east of Naracoorte.

SEA Gas currently owns and operates the SEA Gas Pipeline under Pipeline Licence 13 (PL13). It is proposed that the Naracoorte Lateral pipeline be authorised as an extension to PL13.

The SEA Gas Project Environment Effects Report / Environmental Impact Report (SEA Gas Project EER/EIR) describes the general environmental impacts of the construction and operation of the main pipeline however it does not cover additional lateral pipelines. This document has been prepared to cover this aspect.

## 1.2 Project Proponent

SEA Gas is a joint venture company established specifically to develop and operate the SEA Gas Pipeline. The company is owned equally by Australian National Power, Origin Energy and TXU.

## 1.3 Environmental Commitment

SEA Gas is committed to responsible environmental management for the construction and operation of the Project and believes that any potential adverse environmental effects can be effectively managed in a manner that complies with the requirements of this document, as well as:

- all relevant State and Commonwealth laws and regulations
- SEA Gas Environmental Policy
- relevant industry standards (such as Australian Standard 2885, EPA guidelines and ANZECC water quality criteria)
- the Australian Pipeline Industry Association (APIA) *Code of Environmental Practice 1998*.

SEA Gas also recognises its community obligation to take all practicable steps to ensure its operations and activities are conducted in an efficient and environmentally sustainable manner.

## 1.4 Regulatory Framework

To support an application for the construction of the Naracoorte Lateral pipeline, SEA Gas must prepare:

- An Environmental Impact Report (EIR) - in accordance with Section 97 of the South Australian *Petroleum Act 2000* (the Act) and Regulation 10 of the *Petroleum Regulations 2000* (the Regulations)
- A Statement of Environmental Objectives (SEO) - in accordance with Section 99 and 100 of the Act and Regulations 12 and 13.

### 1.4.1 Environmental Impact Report

This document fulfils the requirements of an EIR as outlined in the Petroleum Act and Regulations.

### 1.4.2 Statement of Environmental Objectives

A Statement of Environmental Objectives (SEA Gas, November 2002) was produced and approved for the SEA Gas Project. It outlines the environmental objectives with which pipeline construction, operation and decommissioning activities must conform and the criteria upon which achievement of these objectives will be assessed.

The existing SEA Gas Project SEO was reviewed to determine if the proposed extension to the pipeline at Naracoorte would be adequately covered by this document. It was concluded that the existing SEO adequately covers the objectives and assessment criteria associated with this extension to the SEA Gas pipeline, primarily because the construction methods and potential environmental impacts involved in the pipeline extension are consistent with the methods and impacts identified for the SEA Gas pipeline.

In particular, pipeline construction and operation in the Naracoorte region, through farming areas where there are scattered remnant trees, were considered in the SEA Gas Project EER/EIR and relevant objectives were included in the SEO. Section 5 of this report provides a list of the objectives contained in the existing SEO that address these potential environmental impacts.

Therefore, the existing SEA Gas Project Statement of Environmental Objectives (November 2002) adequately covers the proposed extension to the pipeline licence, and has not been revised.

### 1.4.3 Other Legislation and Approvals

Detailed discussion of the regulatory framework relevant to this Project is included in Chapter 2 the SEA Gas Project EER/EIR. It provides information on other relevant State and Commonwealth approvals and legislation, including:

- South Australia
  - *Aboriginal Heritage Act 1988*
  - *Heritage Act 1993*
  - *Water Resources Act 1997*
  - *Environment Protection Act 1993*
  - *Native Vegetation Act 1991*
- Commonwealth
  - *Environmental Protection and Biodiversity Conservation Act 1999*
  - *Native Title Act 1993*
  - *Aboriginal and Torres Strait Islander Heritage Protection Act 1984.*

## **Native Title**

There is no registered Native Title claim over the Naracoorte region. A land titles search has indicated that Native Title is not likely to apply to the proposed pipeline routes, and this is being confirmed. If Native Title is found to apply, SEA Gas will consult with the Department of Aboriginal Affairs and Reconciliation (DAARE) and the Crown Solicitor to determine the appropriate course of action.

## **1.5 About This Document**

This Environmental Impact Report (EIR) has been prepared to support the application for an extension to the SEA Gas Project Pipeline Licence (PL13) at Naracoorte, from KP 286.3 on the SEA Gas Pipeline to a meter station at the Teys Brothers Abattoir.

The document:

- provides a description of the proposed Naracoorte Lateral pipeline
- describes the specific features of the environment that can reasonably be expected to be affected by pipeline construction and operation activities
- identifies potential environmental impacts and consequences
- proposes measures to mitigate potential environmental impacts and consequences
- summarises stakeholder consultation.

As a comprehensive EIR has already been prepared for the SEA Gas Project, this document only seeks to provide additional information on the specific issues associated with the lateral pipeline at Naracoorte. Consequently it does not repeat information relating to the general aspects of the proposed pipeline but, where applicable, makes reference to the SEA Gas Project EER/EIR.

Figure 1: Proposed Naracoorte Lateral Pipeline Alignment

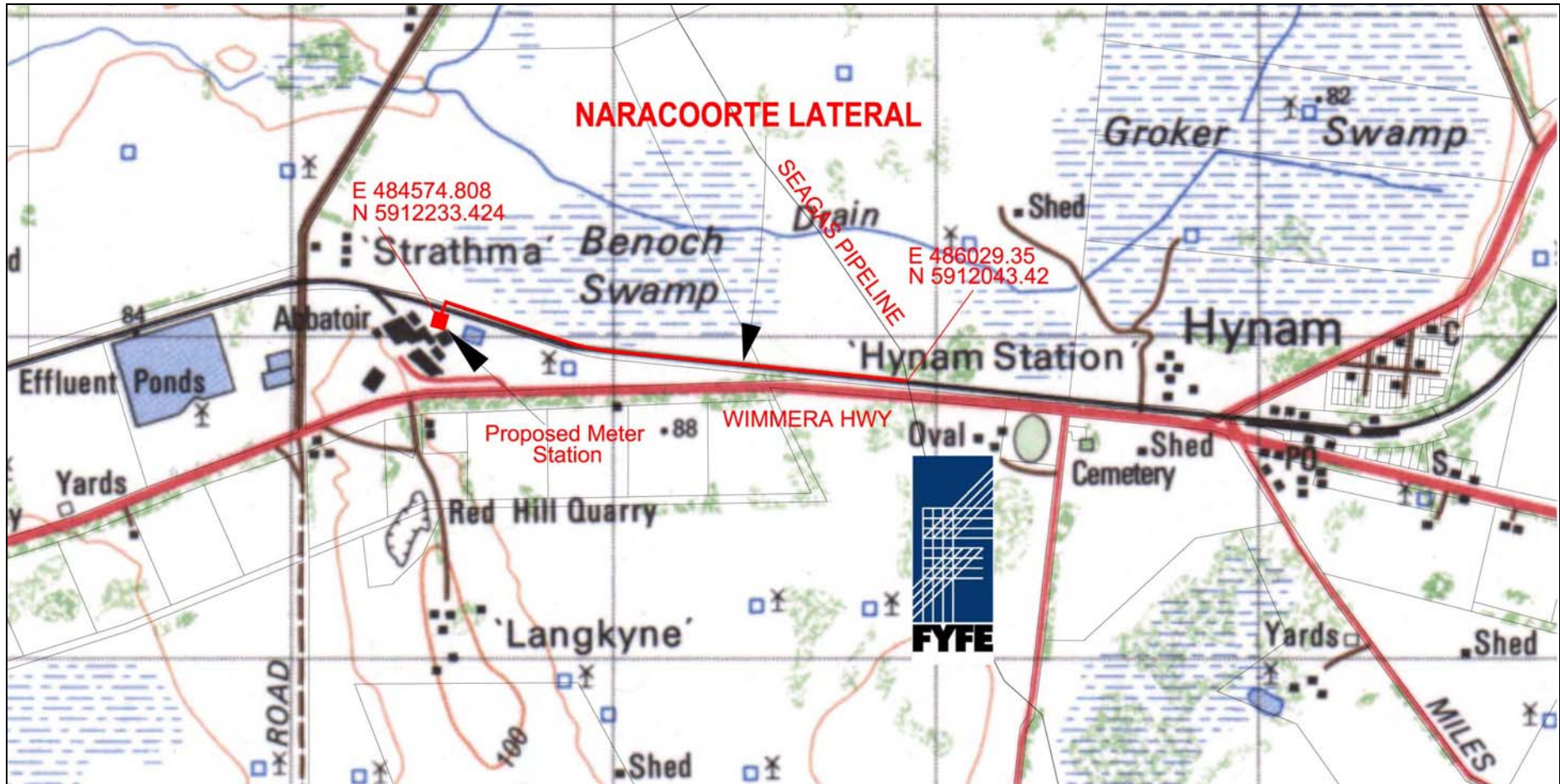

# 2 Project Description

## 2.1 Project Overview

The proposed Naracoorte Lateral project involves construction and operation of a lateral pipeline from a off-take valve at KP286.3 on the SEA Gas pipeline to the Teys Bros Abattoir (located approximately 8km east of Naracoorte) and the construction of a meter station at the abattoir site. The pipeline will be approximately 1.5 km long. The proposed route at Naracoorte traverses farming paddocks adjacent to the disused Wolseley - Mt Gambier Railway line, which lies on the north side of the Wimmera Highway (see Figure 1).

The SEA Gas pipeline consists of twin 350 mm pipes at the off-take location. Gas will be taken from the south-western pipeline only.

## 2.2 Project Schedule

The construction of the Naracoorte Lateral is scheduled to commence in November 2004 and be completed by December 2004.

## 2.3 Design and Engineering

The proposed Naracoorte Lateral pipeline will be designed in accordance with the Australian pipeline standard AS2885:1997 - Gas and Liquid Petroleum. Key engineering and design features of the pipeline are provided in Table 1.

**Table 1: Pipeline Engineering and Design Features**

Design Element	Details
Length	1.5km
Diameter (outside)	60.3 mm
Wall Thickness	5.54 mm
Pipe quality	ASTM A106 Grade B
Factory Coating	HDPE
Pipeline Content	Dry Natural Gas (odorised)
Operational Pressure	3,500 to 14,000 kPag
Maximum Allowable Operating Pressure	15,306 kPag (current) 16,800 kPag (possible future)
Hydrotest Pressure	21,000 kPa (125% of operating pressure)
Design capacity	110 TJ/a
Standard Construction / Operation Easement Width	15m

Design Element	Details
Minimum depth of cover	In accordance with AS 2885, typically: <ul style="list-style-type: none"> <li>▪ Cross Country Sections – 900mm</li> <li>▪ Beneath Roads – 1200mm</li> <li>▪ Beneath Railways – 2000mm</li> </ul>
Corrosion Protection	External Coating and impressed current cathodic protection
Non-destructive Testing	100% radiography of welded joints
Buried marker tape	Installed along the full length, except at bored crossings, at a minimum of 300mm above the pipe
SCADA	Pipeline monitoring and line break protection system

The meter station will also be designed in accordance with all relevant legislation and standards.

## 2.4 Construction

Standard pipeline construction practices will be adopted for the proposed Naracoorte Lateral pipeline. Construction techniques will be in accordance with the Australian Pipeline Industry Association *Code of Environmental Practice*. Construction techniques are described in detail in the SEA Gas Project EER/EIR, however it refers to the construction of a much larger diameter pipeline. The construction of the lateral pipeline will be much smaller in scale and will follow the sequence outlined in Table 2.

**Table 2: Pipeline Construction Sequence**

Construction Activity	Description
Detailed Survey	Engineering, environmental and cultural heritage surveys are used both in route selection and to determine if any special construction techniques or mitigation measures are required. Once the preferred pipeline route has been determined, then the centreline is surveyed and engineering aspects are finalised. Markers (pegs) are placed to identify pipeline route and right-of-way.
Fencing	Severed fences are replaced with construction gates.
Clear and Grade	Graders and bulldozers are used to clear the right-of-way of vegetation and topsoil ready for construction to commence. Vegetation and topsoil is stockpiled separately on the right-of-way. Topsoil will typically be graded to a depth of 100 to 150 mm for a blade-width over the trench line or the entire non-working side or the full right-of-way, depending on factors such as the soil type, terrain, construction requirements and weather conditions.
Trenching	After the route is cleared, a trench (approx. 1.0 metres in depth) is dug for the pipeline either by a trenching machine or excavator. Trench spoil is stockpiled on the right-of-way, usually on the non-working side. Top soil from the trench, to a depth of 600 mm, will be stockpiled separately from the subsoil.
Stringing	Steel pipe is trucked to the construction site and sections, each approximately 12 metres long, are laid end-to-end next to the trench. The sections are placed on sandbags that are raised on blocks of wood (timber skids) to protect the pipe from corrosion and coating damage.
Bending	Where required, pipe sections are bent to match changes either in elevation or direction of the route.
Welding	Pipe sections are welded together.
X-raying	The pipes are inspected using x-ray equipment as per AS 2885.2-1995.
Joint Coating	The area around the weld is then grit blasted and coated, with a protective coating to reduce corrosion
Padding	Where required, padding machines are used to sift the excavated subsoil to remove coarse materials. To protect the pipe coating the remaining fine material is used to pad beneath and on top of the buried pipe. In some instances (e.g. very rocky soils) imported sand or foam

Construction Activity	Description
	pillows are used for padding.
Lowering-in	Sidebooms (bulldozers with cranes) or excavators are used to lower the welded pipe into the trench.
Backfilling	Trench spoil (subsoil and topsoil) is returned to the trench and material compacted to minimise risk of subsidence of material over the pipe.
Pressure Testing	Pipeline integrity is verified using hydrostatic testing in accordance with AS 2885.5. During hydrostatic testing the pipeline is capped with test manifolds, filled with water and pressurised up to 125% of operating pressure for a minimum of two hours. A 24-hour leak test or a 3-hour combined strength and leak test then follows. Providing it meets water quality guidelines and has landholder approval, hydrotest water is discharged to the surrounding environment. If water fails to meet quality guidelines it will be treated prior to disposal eg. by chemical neutralisation. Hydrotest water is sometimes treated with chemicals such as biocide, oxygen scavengers and corrosion inhibitors prior to testing. An oxygen scavenger may be used in this instance, however this may not be necessary due to the small size of the lateral and subsequent short period of testing.
Restoration and Rehabilitation	The easement is recontoured to match surrounding landform and erosion controls constructed where appropriate. Separately stockpiled topsoil is then respread evenly across the easement and any cleared vegetation placed across the easement, to assist in soil retention and provision of seed stock.  Reseeding or revegetation of the easement, using appropriate species (i.e. crops/pasture or indigenous native species) is undertaken to restore vegetation cover.
Signage	Information signs are erected along the easement as per AS 2885.1-1997.

The Naracoorte Lateral pipeline will be constructed in a 15m wide right-of-way. Typical construction layout is shown in Figure 2.

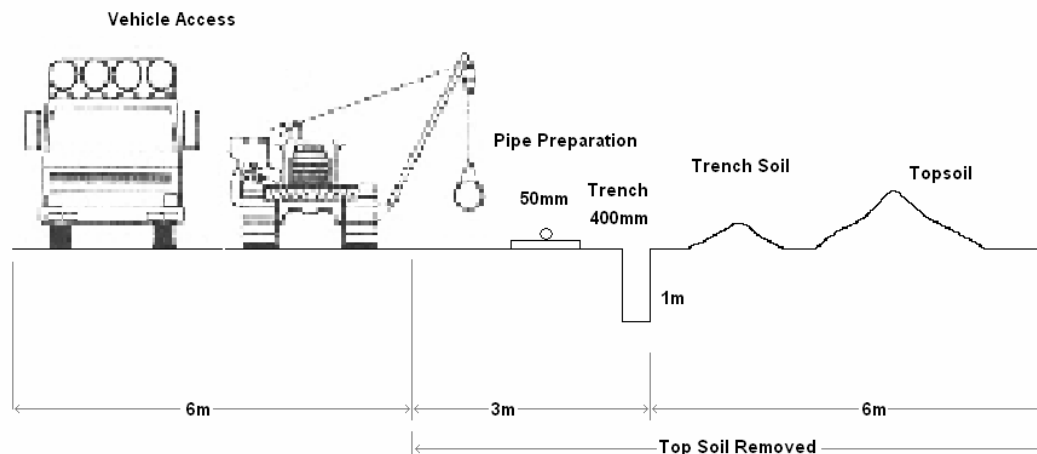

**Figure 2: Typical Layout of Construction Right-of-Way for a Small-Bore Pipeline**

Road or rail crossings will be carried out in accordance with local municipality or railway owner/operator requirements, the Pipeline Code of Practice and AS 2885.1-1997.

The construction workforce is expected to consist of approximately 20 people, including the project management and pipe supply/distribution personnel. In general, no more than 12 personnel are expected to be on site at any given time.

A Construction Environmental Management Plan (CEMP) will be developed for the Naracoorte Lateral. It will outline the environmental objectives, roles and responsibilities for environmental management, site specific environmental management procedures, training programs and monitoring, auditing and reporting systems.

## 2.5 Operation

Pipeline commissioning for the Naracoorte Lateral is scheduled for December 2004. Gas delivery will be controlled from the SEA Gas Control Centre in Adelaide.

Following reinstatement and revegetation of the construction right-of-way, very little above-ground infrastructure will be visible. Above ground infrastructure will be limited to marker posts to identify the location of the pipeline and the meter station, which will be located inside the boundaries of the abattoir at Naracoorte.

Environmental impact associated with operating gas pipelines is minimal and is generally associated with access and potential emissions (venting).

## 2.6 Decommissioning

The design life of the Naracoorte Lateral pipeline is 40 years. When the utility is no longer required, the pipeline will be decommissioned in accordance with the legislative requirements of the day.

## 2.7 Project Rationale and Alternatives

The SEA Gas lateral pipeline has been proposed in direct response to a request from a potential customer to assist them with their natural gas needs.

The Teys Bros abattoir contains three large boilers, a small blood drier and slaughter floor room heaters. Currently, these items are fired using butane. Teys Bros plans to modify these units to run on natural gas from the lateral pipeline, which will be more economical overall.

### 2.7.1 Pipeline Corridor Alternatives

The proposed route along the northern side of the railway line was selected as it is direct and has minimal impact on vegetation and land use. Alternative routes on the southern side of the railway line were investigated, but were not considered feasible due to potential impacts on roadside trees and on the small holding yards adjacent to the abattoir.

# 3 Management of Environmental Issues

This section describes the existing environment along the proposed lateral pipeline alignment, the potential impacts to the environment as a result of pipeline construction and operation and proposed impact mitigation strategies.

Identification of potential impacts and mitigation strategies are based on environmental issues (such as soils and terrain, ecology and heritage) rather than construction activity (such as clearing, trenching and welding). More detailed management procedures for specific tasks will be included in the Construction Environmental Management Plan (CEMP).

This document only addresses issues specifically relevant to the Naracoorte Lateral pipeline. More detailed information in the context of the entire SEA Gas pipeline is contained in the SEA Gas Project EER/EIR.

## 3.1 SEA Gas Environmental Management Strategy

SEA Gas has developed an environmental management strategy for the Project and will develop a Construction Environmental Management Plan for the construction of the lateral pipeline. Details of this strategy are provided in Section 5.2 of the SEA Gas Project EER/EIR.

## 3.2 Climate

The Naracoorte Lateral lies within the South East region of the state. The area has a cool, moist climate with cool, wet winters and long, mild, dry summers. The temperature ranges from a mean minimum of 4.9°C in July to a mean maximum of 28.8°C in February. Rainfall has a strong seasonal distribution (i.e. predominantly winter rainfall) with a mean annual rainfall of 580mm (Bureau of Meteorology 2004).

## 3.3 Soils and Terrain

### 3.3.1 Existing Environment

The region surrounding the Naracoorte Lateral is comprised of plains and swamps. The lateral is located on relatively level ground, and enters a slight depression as it traverses the southern boundary of the adjacent Benoch Swamp.

Soils along the alignment are red-brown sandy clay loam, grading to grey clay on the margins of Benoch Swamp. Soils in the region are generally not considered to be susceptible to water erosion but are prone to wind erosion (PIRSA 2004).

Recent excavations at the proposed meter station site have indicated the presence of 350-450 mm of fill material, mostly clay and gravel. The site was previously farming land prior to the establishment of the abattoir in 1972, and the site history does not indicate a the presence of contaminated material is likely (Steve Pitman, pers. comm.).

The land use in the area (agriculture) indicates that it is unlikely that contaminated soils are present in the proposed construction corridor.

### 3.3.2 Potential Impacts

Potential impacts to soils as a result of pipeline construction are outlined in detail in Section 6.2 of the SEA Gas Project EER/EIR. Construction of the Naracoorte Lateral pipeline may result in the following potential adverse impacts to soils and terrain:

- possible erosion associated with earthworks (e.g. erosion of stockpiled soil)
- compaction of soils
- subsidence over the pipeline
- changes in soil structure through mixing of topsoil and subsoil
- contamination of soils by fuel, oils or chemicals (small quantities of fuel, oils and chemicals may be kept on-site for operation/maintenance of vehicles and equipment).

### 3.3.3 Impact Mitigation

Mitigation measures detailed in Section 6.3 of the SEA Gas Project EER/EIR will be followed to minimise adverse effects to soils. Mitigation measures will include:

- restriction of construction activities to the construction right-of-way
- construction will be scheduled for dry periods of the year. In the event of rain and wet soils, movement of vehicles and equipment along right-of-way will be minimised or avoided
- ripping any areas of compacted soil as part of reinstatement works
- prompt reinstatement of the right-of-way and any associated access tracks upon completion of construction works
- assessment of hydrotest water quality before disposal to meet water quality guidelines
- implementation of appropriate storage and handling procedures for fuels and chemicals (e.g. labelling, bunding)
- topsoil and subsoil will be stockpiled separately
- trench spoil will returned to the trench and compacted
- construction activities will be monitored for excessive dust generation. Dust control measures (eg. use of water carts) will be implemented if excessive dust generation occurs.

## 3.4 Hydrology

### 3.4.1 Existing Environment

The proposed construction corridor at Naracoorte is located adjacent to Benoch Swamp, which has been cleared and drained but is subject to seasonal inundation. No watercourses are present on the alignment, however a small drain crosses the proposed alignment and drains through Benoch Swamp to the north (Plate 1).

Groundwater is present near the surface in the region and the watertable can be exposed during winter (SEA Gas 2001). Extensive rainfall can cause localised flooding for prolonged periods.



**Plate 1: Small Drain Across Easement (Facing South Across Easement)**

### 3.4.2 Potential Impacts

Potential impacts to surface and ground water as a result of pipeline construction are outlined in Chapter 7 of the SEA Gas Project EER/EIR. At the Naracoorte sites, the most relevant of these are:

- increased sediment load and turbidity in surface drains
- interruption or modification of surface or ground water drainage patterns
- potential contamination of surface or ground water by minor spills of fuel or chemicals or discharged hydrotest water.

### 3.4.3 Impact Mitigation

Mitigation measures outlined in Chapter 7 of the SEA Gas Project EER/EIR will be implemented to minimise adverse effects to hydrology of the area. In particular, the following will be implemented:

- construction will be scheduled for dry periods of the year
- material will be stockpiled away from watercourse banks
- adequate erosion and sediment controls will be in place
- procedures for management of discharged hydrotest water will be included in the CEMP
- trench dewatering to watercourses or unstable land will be avoided
- the trench will be compacted to a level consistent to surrounding soils to avoid impeding groundwater flows
- vehicle refuelling will be prohibited within 50m of a watercourse
- spill prevention, response and cleanup procedures (including refuelling techniques and chemical storage and handling requirements) will be included in the CEMP.

## 3.5 Noise Emissions

### 3.5.1 Existing Environment

The Naracoorte Lateral is located in a predominantly rural setting. Ambient noise levels at the off-take location are dominated by rural activity and traffic along the Wimmera Highway. Closer to the abattoir, noise from the abattoir associated with large numbers of animals, machinery, vehicles and the processing plant dominate the noise environment. The abattoir typically operates 12 hours per day from 5am to 5pm, 5 or 6 days per week, although some elements of the plant (e.g. the cooker for rendering) operate through the night.

The project area is not densely settled, with the closest residence over 300m from the pipeline easement.

### 3.5.2 Potential Impacts

Noise emissions will be produced during both the construction and operation of the pipeline.

#### Construction

Pipeline construction activity will result in a temporary increase in noise levels associated with the operation of vehicles and equipment such as excavators, graders, bulldozers and boring equipment. Blasting is extremely unlikely to be carried out.

Noisy construction activities at stationary and long-term work sites is permitted between 7.00am and 6.00pm, Monday to Saturday and between 9.00am and 6.00pm on Sunday (EPA Information Sheet *Construction Noise – July 2002*).

#### Operation

Noise emissions associated with the operation of the pipeline will include the continuous operation of the gas metering and pressure regulation station, and occasional operation of the pressure safety valves.

Noise from industrial premises is controlled by the *Environment Protection (Industrial Noise) Policy 1994*. This states that the allowable noise level is the maximum of:

- 5 dB(A) greater than the background noise level
- the maximum allowable noise level scheduled for the particular area.

In rural areas, the maximum allowable noise level under the policy is 47 dB(A) in the daytime, and 40 dB(A) at night (10 pm – 7 am). Maximum allowable levels for other land uses are higher. Because intensive rural activity (wineries, produce processing) does not fit easily into the land use descriptions in the policy, it is becoming more usual that they be treated similar to light industry or urban residential with some industry.

The policy is used to assess noise from existing situations, and is not strictly applicable for planning new developments. Current practice, and the EPA, suggests that an environmental noise design criterion of 5 dB(A) lower than the noise level set out in the policy be used for assessing environmental noise in a planning context. This results in a rural planning criterion of 35 dB(A) which has been adopted for this assessment.

Existing ambient noise levels have not been measured, however it is expected that the presence of the abattoir may result in higher than rural noise levels. These could be assessed if steady noise levels are expected to be greater than the rural planning criterion of 35 dB(A).

Another relevant criterion that is not addressed in the *Environment Protection (Industrial Noise) Policy* is in relation to higher level short term noise ingress. The EPA recommend use of 60dB(A) as maximum short term noise level, based on World Health Organisation sleep disturbance criteria<sup>1</sup>. On this basis, the environmental noise criterion for short term noise from the pressure safety valves is 60 dB(A) maximum.

#### Noise Assessment Methods

A noise assessment has been undertaken by Bassett Acoustics to consider environmental noise at residential locations near the abattoir. Noise sources assessed were:

- steady regulator noise radiating from the exposed pipe-work with the maximum level of 72 dB(A) at 1 m for the stage 1 regulator and 80 dB(A) at 1 m for the stage 2 regulator
- short term noise from the low pressure and intermediate pressure safety valves, with noise levels based on modelling of choke flow (shock) noise and turbulent flow noise.

Environmental noise levels were predicted at three nearest residences, located as follows:

- R1: 400 m north-west
- R2: 300 m south with shielding from the abattoir buildings
- R3: 500 m south-west.

Weather was assumed to be “worst case” i.e. conducive to noise propagation. This occurs with a wind from the source to the receiver and either a clear night or an overcast day. Levels can be up to 15 dB(A) lower for other conditions. Environmental noise levels were predicted using CONCAWE algorithms in SoundPLAN noise propagation software.

#### Noise Assessment Results

Predicted levels for continuous noise from the meter station were well within the EPA environmental noise criterion for rural locations. Predicted levels were:

- R1: 24 dB(A)
- R2: 28 dB(A) (without consideration of shielding)
- R3: 22 dB(A).

Predicted levels for short-term pressure safety valve noise are listed in Table 3. The low pressure valve just exceeds environmental (sleep disturbance) criteria. Given the “worst case” assumptions regarding the sound power level and noise propagation, and given that the abattoir building is expected to provide some shielding to residence R2, the 60 dB(A) criterion is unlikely to be exceeded.

Noise predictions indicate that the intermediate stage pressure safety valve will require discharge attenuation of a minimum of 25 dB(A) to meet environmental (sleep disturbance) criteria. This can be readily achieved, for example using a multistage let-down attenuator or a combined multistage let-down with absorptive element attenuator.

**Table 3: Predicted Maximum Pressure Safety Valve Noise – dB(A)**

Valve	Location		
	5m	R1	R2 (no shielding)
Low pressure	98	60	64
Intermediate pressure	123	85	89

<sup>1</sup> Berglund, Lindvall and Schwela, 1999, “Guidelines for Community Noise”. World Health Organisation.

### 3.5.3 Mitigation Measures

Mitigation measures outlined in Section 8.2.3 of the SEA Gas Project EER/EIR will be followed to minimise adverse noise impacts. In particular the noise impacts shall be mitigated through the following measures:

- under normal operating conditions, construction will be scheduled in accordance with EPA recommendations (EPA Information Sheet *Construction Noise – July 2002*)
- local residents will be consulted if unavoidable out-of-hours work is required
- all vehicles and equipment shall conform to appropriate noise control standards
- attenuation will be applied to the intermediate pressure safety valve to ensure noise levels meet the 60 dB(A) environmental (sleep disturbance) criteria at nearby residences.

## 3.6 Atmospheric Emissions

### 3.6.1 Existing Environment

Air quality in the project area is expected to be reasonable. The surrounding environment is predominantly rural, and there are few emission sources in the project area. Operations at the abattoir are expected to emit small amounts of pollutants such as carbon monoxide and nitrous oxides as a result of butane combustion in the boilers, heaters and driers, as well as particulate matter from drying of blood and other by-products. Vehicle emissions are considered to be the only other significant source of pollutants.

### 3.6.2 Potential Impacts

Minor emission pollutants such as nitrous oxides, sulphur oxides and carbon monoxide are associated with the exhausts of machinery and support vehicles. Construction phase emission impacts are expected to be minimal due to the short-term nature of the project. The impact of air quality and Greenhouse gas emissions will be insignificant.

Dust resulting from construction and restoration activities on the right-of-way is the most likely air quality hazard. Dust generation is expected to be localised and restricted to construction and restoration phases of the project. Impacts are expected to be minor.

The release of gas from the pipeline will be minimised for economic, environmental and greenhouse gas emission reasons. Pipeline venting is expected to occur in association with pipeline commissioning and may occur if required as part of maintenance activities during operations. The impacts on air quality and Greenhouse gas emissions will be insignificant.

### 3.6.3 Mitigation Measures

Mitigation measures outlined in Section 8.1.3 of the SEA Gas Project EER/EIR will be followed to minimise adverse effects to air quality in the construction areas. These include:

- regularly maintaining and servicing machinery and vehicles
- minimising the period between clearing and restoration, and limiting vehicle speeds on the pipeline easement or access roads
- implementing dust suppression measures, such as water carts, where required.

Where practical, planned gas releases shall be conducted under favourable meteorological conditions that will facilitate rapid atmospheric dispersion of the gas.

## 3.7 Flora and Fauna

### 3.7.1 Existing Environment

An assessment of the flora and fauna of the proposed alignment at Naracoorte was undertaken on 26th July 2004 by Stephen Milne (Ecos Consulting). Vegetation and habitat along the length of the proposed alignment were inspected.

#### Flora

Plant species recorded within the pipeline easement are listed in Table 4. Most annual plant species had recently germinated at the time of the survey, and many could not be identified to species level. However, it is not expected that additional native species are present on the easement, due to the heavily disturbed nature of the site.

The pipeline alignment predominantly passes through cropped paddocks. The only native vegetation noted in these paddocks was large, scattered remnant River Red Gums (*Eucalyptus camaldulensis*). Two of the three paddocks the pipeline passes through had recently been sown to crops. The third paddock has been previously cropped and was dominated by exotic pasture grasses, Cape Weed (*Arctotheca calendula*) and Onion Grass (*Romulea* sp.).

Three large River Red Gums are present within the 15 m easement and are located approximately 10 m from the fence line (Plate 2).



**Plate 2: Pipeline Alignment Showing Large Red Gums on Easement**

The vegetation of the rail reserve to the south of the pipeline easement is dominated by introduced weeds (mainly Canary Grass, *Phalaris* sp.) and River Red Gums are present along much of its length. Small patches of remnant native vegetation were noted inside the fenced rail reserve near the off-take valve. Species recorded included Kangaroo Grass (*Themeda triandra*), Speargrass (*Stipa* sp.), and Black-Anther Flax-Lily (*Dianella revoluta*).

Within the abattoir grounds, the meter station site and its surrounds are vegetated with introduced grasses and planted trees, which are mostly exotic species (Plate 3). One small ash tree (*Fraxinus* sp.) is present on the meter station site and will need to be removed.



**Plate 3: Proposed Meter Station Site**

**Table 4: Plant Species Recorded on the Easement**

Plant Species	Common Name
* <i>Arctotheca calendula</i>	Cape Weed
*Compositae spp.	Thistle
<i>Eucalyptus camaldulensis</i>	River Red Gum
* <i>Fraxinus</i> sp.	Ash
*Graminae spp.	Grasses
* <i>Plantago</i> sp.	Ribwort
* <i>Phalaris</i> sp.	Canary Grass
* <i>Romulea</i> sp.	Onion Grass
* <i>Rumex</i> sp.	Dock
* <i>Trifolium</i> sp.	Clover

\*Denotes alien species

## **Fauna**

Common agricultural bird species (e.g. magpies and kookaburras) and stock were the only fauna species observed on or near the proposed alignment during the site inspection. Snakes (probably brown snakes, *Pseudonaja textilis*) have been observed on previous visits. Due to the highly disturbed nature of the site, additional native terrestrial species are not likely to be present.

The region around Naracoorte is known to contain breeding, feeding and nesting habitat for the nationally endangered Red-tailed Black Cockatoo (*Calyptorhynchus banksii graptogyne*).

This species predominantly feeds on the fruit (seeds) of the Brown Stringy Bark (*E.baxteri* and *E.aranacea*) throughout the year, however food preferences may change with seasonal availability. Breeding occurs between October and May (predominantly between August and December) and the birds nest in hollow trees.

The main nesting tree used by this species is the river red gum with over 90% of nests recorded in these trees, usually in dead trees (88%) on private land (Hill 1998, Joseph *et al* 1991). Most nesting trees (98%) have been found to be located within 2km of feeding habitat (i.e. blocks of Brown Stringy Bark >5ha).

Large River Red Gums with hollows are present within the vicinity of the pipeline easement, so there is some potential for nesting red-tailed black cockatoos to be present. Nesting has not been previously recorded in the immediate vicinity of the pipeline alignment, and a survey for nesting red-tailed black cockatoos in the vicinity of the off-take valve undertaken in the 2002 nesting season did not detect any nesting activity.

### 3.7.2 Potential Impacts

The overall impact of clearing the right-of-way is not considered significant as existing vegetation is highly disturbed with no remnant species apart from scattered River Red Gums. The proposed alignment does not require clearing of any remnant trees or shrubs, as clearance of the three large River Red Gums within the easement will be avoided.

Some indirect damage to the River Red Gums on the alignment may occur as a result of soil compaction under their canopies by vehicles and equipment and trenching within the canopy line. Trimming of some branches overhanging the easement from River Red Gums inside the rail reserve may be required, but other indirect impact on native species inside the fenced rail reserve is unlikely.

Weeds are common along the proposed alignment. No sign of disease was noted. There is a limited potential for introduction or spread of weeds and/or disease associated with movement of vehicles and machinery.

The presence of construction personnel and machinery and noise from construction activity has the potential to disrupt nesting Red-Tailed Black Cockatoos. This could result in breeding failure of one or more pairs if they were nesting near the easement. Previous research and consultation undertaken for the SEA Gas Project have established 500 m as a nominal buffer zone for nesting birds, outside which disturbance as a result of pipeline construction is unlikely.

There is some potential for snakes to become trapped in the open trench.

### 3.7.3 Impact Mitigation

Mitigation measures outlined in Section 9.3 of the SEA Gas Project EER/EIR will be integrated into the CEMP, and implemented to minimise adverse effects to flora and fauna. In particular:

- clearance of River Red Gums will be avoided
- trenching will be undertaken as far away from trees as possible, and where practicable, outside the canopy
- parking of vehicles and equipment or stockpiling materials under River Red Gums will be avoided
- impact to vegetation inside the rail reserve fence-line will be avoided
- if required, trimming of branches overhanging the easement will be undertaken using a chainsaw, following the 'three-cut' method

- the period in which the trench is open will be minimised
- the trench will be regularly inspected for the presence of fauna and an appropriately licensed person used if native fauna handling is required
- if construction is to be undertaken during Red-Tailed Black-Cockatoo nesting periods, a survey will be undertaken to determine if nesting birds are present. If nesting Red-Tailed Black Cockatoos are present within 500m of the pipeline, appropriate management and monitoring strategies will be determined in consultation with the Red-Tailed Black Cockatoo Recovery Team and the Commonwealth Department of the Environment and Heritage.

## 3.8 Cultural Heritage

### 3.8.1 Existing Environment

An Indigenous and non-Indigenous cultural heritage study of the proposed pipeline was conducted by Vivienne Wood, a qualified archaeological consultant. A field survey was conducted on Friday August 6 2004. The consultant was accompanied in the field by three representatives of the Tattyara Aboriginal Heritage Consultancy: Kerry Hunt, Frank Hunt and Jessie Clarke.

The team walked the entire length of the pipeline alignment, from the SEA Gas pipeline in the east, to the abattoir in the west. All mature gum trees close to the proposed alignment were checked for evidence of intentional scarring with none being found.

Ground surface visibility ranged from 0 – 60% with pasture grasses and crops obscuring visibility in many locations. In addition, much of the area was under water making access difficult.

No sites of significance to Aboriginal tradition, history, anthropology or archaeology were found during the survey and it is considered unlikely that any will be unearthed during excavations associated with the project. One non-Indigenous heritage site was recorded during a previous survey for the SEA Gas pipeline alignment, the disused Wolseley – Mt. Gambier rail line, but this will not be disturbed during construction of the present project as the pipe is to be bored under the line from the paddock south to the abattoir. No further non-Indigenous sites were recorded during the present study.

### 3.8.2 Potential Impacts

Potential impacts to indigenous heritage as a result of construction activities are outlined in Chapter 10 of the SEA Gas Project EER/EIR.

Given that no European heritage or Aboriginal archaeological sites were found during the survey, there is no foreseeable impact to known European heritage or Aboriginal sites and therefore there are no archaeological constraints on construction activities

### 3.8.3 Impact Mitigation

The mitigation measures proposed in Section 10.1.3 of the SEA Gas Project EER/EIR will be implemented to minimise adverse impacts to heritage. In particular, if cultural material, particularly human burials, should become evident during construction activities, work in the vicinity will cease immediately and contact will be made with the Department of Aboriginal Affairs and Reconciliation, as well as Kerry Hunt of the Tattyara Aboriginal Heritage Consultancy, who will assess the situation. These procedures will be incorporated into the Construction Environmental Management Plan.

## 3.9 Land Use

Chapter 11 of the SEA Gas Project EER/EIR outlines a range of potential social issues, including impacts to land use, visual amenity and third party infrastructure. Specific issues relevant to the Naracoorte Lateral are summarised below.

### 3.9.1 Existing Environment

The main land use in the region and along the alignment is broad-acre farming and grazing. Land parcels in the region are relatively large and the population density is moderate to low.

There is no noted areas of conservation significance within the vicinity of the pipeline.

### 3.9.2 Potential Impacts

The Naracoorte pipeline is small in scale and impacts to land use are expected to be minor. Localised impacts can be summarised as:

- short-term reduction in availability of cropping land
- potential introduction or spread of agricultural weeds or diseases
- temporary replacement of permanent fences with access gates
- short term disturbance to stock associated with noise and human activity
- potential injury to, or mortality of, stock in the open trench
- risk of fire associated with welding and the use of vehicles and machinery in paddocks.

### 3.9.3 Impact Mitigation

Impact mitigation measures are discussed in detail in Section 11.2 of the SEA Gas Project EER/EIR. Appropriate mitigation measures include:

- vehicles and machinery will be clean and free of weeds before entering the project area
- disturbance to crops shall be restricted to the 15m right-of-way
- access shall be restricted to that which is essential for pipeline construction and operation
- all vehicles shall carry fire extinguishers
- the exact location of services shall be determined before construction proceeds
- the pipeline shall be buried to a minimum depth of 900 mm, thereby allowing cropping to continue following completion of pipeline construction
- all fences shall be reinstated following rehabilitation of the easement
- landholders shall be compensated for any loss of production associated with the project.

## 3.10 Public Risk and Safety

### 3.10.1 Existing Environment

The project area is classified as "Rural Land" R1 under AS2885, with residences located significant distances apart. The main transport corridor in the project area is the Wimmera Highway, which is south of the construction right-of-way.

### 3.10.2 Potential Impacts

The potential impacts to public safety are fire, explosion or radiation exposure as a result of pipeline rupture. The main potential causes of damage or pipeline failure are considered to be:

- heavy vehicle traffic
- corrosion of the pipeline (external or internal)
- natural events which stress the pipeline (e.g. earthquake)
- excavation in the easement by third parties
- overpressure
- metallurgical or construction faults.

Injury to third parties is also a potential impact of construction activities. Hazards include construction work across roads, increased heavy vehicle traffic in the project area and dust generation. Hazards associated with dust are discussed in Section 3.6.

### 3.10.3 Mitigation Measures

Mitigation strategies include:

- a detailed risk assessment shall be undertaken in accordance with AS 2885
- appropriate protective measures (e.g. deep burial, concrete slabs) shall be installed where determined to be necessary by risk assessment
- appropriate signage, in accordance with project traffic management plans, shall be installed during construction and operation to clearly identify the presence of construction vehicles and the pipeline
- the design, installation and commissioning process shall be in accordance with relevant codes, in particular AS 2885.1-1997
- appropriate safety measures shall be undertaken where construction activities occur adjacent to or across roads
- the pipeline line will be pressure tested prior to commissioning to ensure integrity of pipes and welds
- a comprehensive corrosion prevention program shall be implemented;
- all welded joints shall be subject to x-ray inspection during construction to ensure integrity of welds
- regular liaison shall be conducted with landholders and local residents to inform them of the schedule of construction works
- monitoring of the pipeline from SEA Gas's Gas Control Centre in Adelaide and by locally based field inspectors.

## 3.11 Hazardous Storage, Spill and Emergency Response

A limited amount of chemicals and hazardous substances may be required on site for the construction of the pipeline. These may include fuel, lube oils, solvents, rust-proofing agents and primer, as outlined in Section 11.7 of the SEA Gas Project EER/EIR.

Potential impacts include contamination of soils and water resources, as discussed in Sections 3.3, 3.4 and 3.7 of this EIR and in Sections 6, 7 and 9 of the SEA Gas Project EER/EIR.

Mitigation measures outlined in the SEA Gas Project EER/EIR will be followed, including:

- hazardous material will not be stored or drained onto the ground or onto watercourses or floodplains
- all fuels and hazardous materials used on-site will be appropriately stored and (bundling as per regulatory guidelines)
- vehicles and machinery will not be refuelled within 50m of a floodplain or watercourse

- materials and equipment required to respond to a hazardous spill will be readily available
- appropriate implementation of cleanup/spill response procedures in the event of a spill
- material Safety Data Sheets to be kept for each chemical used on-site and at a location that is easily accessible 24 hrs per day
- all personnel will be instructed in Project prevention, safety and response practices as a component of the environmental induction process.

## 3.12 Additional Mitigation Strategies

### 3.12.1 Construction Environmental Management Plan

A task-specific Construction Environmental Management Plan is being developed for the Naracoorte Lateral pipeline. Specific aspects of the lateral pipeline will be incorporated into this EMP for review by PIRSA prior to construction and implemented during construction.

### 3.12.2 Awareness Program

SEA Gas shall ensure that all personnel and associated contractors are adequately aware of the relevant impact mitigation strategies.

### 3.12.3 Contractual Obligations

All contracts with companies undertaking construction activities for SEA Gas on the Naracoorte Lateral pipeline shall include a requirement to:

- operate in a manner consistent with SEA Gas's Environmental Policy
- adopt mitigation strategies outlined in this EIR
- meet SEO commitments.

# 4 Consultation

SEA Gas recognises that an effective consultation program is an essential part of any project. SEA Gas aim to effectively communicate with all key landholders, stakeholders and other interested parties.

SEA Gas actively sought stakeholder input into the environmental assessment process for construction and operation of the SEA Gas pipeline. Information on stakeholder consultation and SEA Gas's ongoing consultation strategy is provided in Chapter 12 of the SEA Gas Project EER/EIR.

Specific consultation regarding the Naracoorte Lateral pipeline is discussed further below.

## 4.1 Key Stakeholders

The following stakeholders have been identified as having a direct interest in the construction and operation of the Naracoorte Lateral pipeline:

- State regulatory agencies
- Local government
- Landowners/occupiers
- Aboriginal heritage groups and Native Title claimants.

Stakeholder consultation carried out for the Naracoorte Lateral pipeline is summarised in Table 5. Issues raised by stakeholders have been addressed within this EIR where appropriate.

**Table 5: Stakeholder Consultation**

Stakeholder	Key Issues
<b>State Government</b>	
PIRSA Petroleum	<ul style="list-style-type: none"> <li>▪ EIR required for licence extension</li> <li>▪ Ensure adequate information distributed to landholders</li> </ul>
Transport SA	<ul style="list-style-type: none"> <li>▪ No issues</li> </ul>
<b>Local Government</b>	
Naracoorte Lucindale Council	<ul style="list-style-type: none"> <li>▪ Possibility of pipeline to Naracoorte</li> </ul>
<b>Heritage</b>	
State Aboriginal Heritage Committee	<ul style="list-style-type: none"> <li>▪ Indigenous group to consult for a heritage study is the Tattyara Aboriginal Heritage Consultancy</li> </ul>
Tattyara Aboriginal Heritage Consultancy	<ul style="list-style-type: none"> <li>▪ No issues</li> </ul>

### 4.1.1 Landowners/occupiers

The Naracoorte Lateral traverses four land titles (see Table 6).

**Table 6: Landholders on the Naracoorte Lateral Pipeline**

Name	Title Reference
Gericke PM & BN	CT 5894/925
Biggins AS	CT 5832/546
Minister for Transport & Urban Planning	CT 5895/300
Teys Bros (Naracoorte) Pty Ltd	CT 5319/074

Landowners/occupiers on the proposed Lateral pipeline route have been informed of the proposed extension and negotiations for easement acquisition are well advanced. SEA Gas will continue to work closely with landowners/occupiers as the Project progresses.

# 5 Statement of Environmental Objectives

The SEA Gas Project Statement of Environmental Objectives (SEO), November 2002 outlines the environmental objectives with which construction, operation and decommissioning activities must conform and the criteria upon which achievement of these objectives will be assessed.

The construction methods and potential environmental impacts involved in the extension of the SEA Gas pipeline at Naracoorte are consistent with the methods and impacts identified for the remainder of the SEA Gas pipeline.

Because no new construction techniques, additional environmental impacts or required mitigation strategies have been identified for extension of the pipeline, the SEA Gas SEO adequately covers the objectives and assessment criteria relevant to the extension of the pipeline.

In particular, the SEO Objectives listed in Table 7 address the main issues that have been outlined in this EIR. In addition, Section 5 of the SEO contains detailed conditions and requirements that must be complied with in order to meet the objectives and thus address the environmental issues described in this EIR.

**Table 7: Relevant Objectives from the SEA Gas Project SEO (November 2002)**

Issue	Relevant SEO Objectives
Soil	1.1 To limit the occurrence and extent of trench subsidence, soil erosion and sedimentation 1.2 To reinstate soil and terrain to pre-construction contours and conditions 1.4 To avoid soil inversion and if necessary undertake remedial action 1.5 To mitigate soil compaction if necessary by remedial action 1.6 To appropriately protect soils from contamination and to plan for the constraints posed by pre-existing soil contamination
Groundwater	2.1 To prevent significant alteration to hydrological conditions & remediate if required 2.2 To appropriately protect groundwater quality from contamination by fuel, chemicals, acid sulphate soil leachate or other hazardous substances and remediate if required 2.4 To plan for the constraints posed by shallow groundwater to standard construction activities
Surface Water	3.1 To minimise the amount of sediment entering surface water features 3.2 To appropriately protect surface waters from contamination by fuel, chemicals, highly saline groundwater, acid sulphate soil leachate or other hazardous substances 3.3 To minimise short term, and prevent long-term, interruption or modification to surface drainage patterns & remediate if required
Air Quality	5.1 To minimise dust emissions 5.2 To maintain vehicles and construction equipment to minimise air quality impacts

Issue	Relevant SEO Objectives
Noise	22.a To meet regulatory requirements for noise emissions from the Compressor Station and other pipeline infrastructure 22.3 Minimise noise impacts associated with operation of the pipeline and associated infrastructure
Flora and fauna	7.1 To minimise and where practicable avoid clearing of remnant vegetation 7.2 To keep fauna fatalities to as low as possible 7.3 To avoid destruction of significant fauna habitats 7.4 To minimise and where practicable avoid fragmentation of fauna habitats 7.5 To minimise disruption to critical fauna lifecycle stages 7.6 To minimise loss of biodiversity 7.7 To avoid the spread of environmental and proclaimed weeds 7.8 To undertake appropriate actions to destroy environmental or proclaimed weeds <i>Wimmera Plains</i> <ul style="list-style-type: none"> <li>▪ To avoid clearing old growth eucalypts</li> <li>▪ To minimize clearing of Red Gums and Yellow Gums (SA Blue Gums)</li> </ul>
Indigenous heritage	8.1 To protect surface and shallow artefact scatters from damage 8.2 To minimise damage to subsurface material 8.3 To avoid damage to culturally significant vegetation 8.4 To avoid damage to built heritage 8.6 To implement appropriate protocols for dealing with cultural heritage material discovered during construction 8.7 To avoid damage to sites of significance to Aboriginal anthropology or history
Land use	10.1 To prevent adverse effects on stock during construction 10.2 To avoid unacceptable disturbances to landowner assets and infrastructure remediate where required 10.4 To prevent the spread of, and to take practicable measures to control weeds and animal and plant pests and diseases, (such as branched broomrape, phylloxera and footrot), and to take appropriate remediation measures where required 10.5 To avoid adverse effects to residential and industrial activities
Stakeholder consultation	16.3 To identify issues and concerns to provide the opportunity for them to be addressed during project planning, assessment and design 16.5 To establish all necessary agreements with landowner/occupiers directly affected

# 6 Conclusion

The extension of the SEA Gas pipeline licence (Pipeline Licence 13) to include the construction and operation of a lateral pipeline at Naracoorte is a relatively small project that will deliver gas directly to the end-user, the Teys Bros Abattoir near Naracoorte.

SEA Gas has developed this Environmental Impact Report in accordance with the South Australian *Petroleum Act 2000* to address issues specifically relevant to the Naracoorte Lateral pipeline.

The Naracoorte Lateral pipeline involves the construction of infrastructure in a degraded environment of low population density. The pipeline does not impact on environmentally and culturally sensitive areas.

The potential impacts to landholders, the environment and stakeholders are expected to be short-term and minor in extent. No significant long-term adverse impacts are expected.

In managing potential impacts, SEA Gas is committed to working closely with all relevant authorities and landholders. SEA Gas shall take all necessary steps to rehabilitate areas affected by the Project during both construction and operation. As part of these commitments SEA Gas will integrate environmental management principles and procedures into the design and construction processes.

A Construction Environmental Management Plan (CEMP), which will outline the environmental objectives, roles and responsibilities for environmental management, site specific environmental management procedures, training programs and monitoring, auditing and reporting systems will be developed for the Naracoorte Lateral pipeline.

# 7 References

Bureau of Meteorology (2004). Climate Information. <http://www.bom.gov.au/climate/>.

Hill, F.A.R., (1998). Report to RTBC Recovery Team. Cited In: Fendley, M. (2003). Red-tailed Black Cockatoo Education Kit Online. <http://www.birdsaustralia.com.au/rtbcd/intro.htm> (last accessed 25/08/03). Created by Michael Fendley, Threatened Bird Network.

Joseph, L., Emison, W.B. & Bren, W.M. (1991) Critical assessment of the conservation status of the Red-tailed Black-Cockatoo in south-eastern Australia with special reference to nesting requirements. *Emu* 91: 46-50. Cited in: Venn, D.R. and Fisher, J. (1993). Red-Tailed Black Cockatoo *Calyptorhynchus banksii graptogyne*. Flora and Fauna Guarantee Action Statement No 37. Department of Natural Resources & Environment, July 1993.

Neagle, N. (1995). *An Update of the Conservation Status of the Major Plant Associations of South Australia*. Native Vegetation Conservation Section, Department of Environment and Land Management, South Australia.

SEA Gas (2001). *SEA Gas Project Environmental Effects Report / Environmental Impact Report*. SEA Gas, Adelaide.

SEA Gas (2001). *SEA Gas Project Statement of Environmental Objectives, November 2002*. SEA Gas, Adelaide.

PIRSA (2004) *Soil Conservation Districts Planning Maps*. <http://www.soil.pir.sa.gov.au/>

## Personal Communications

Steve Pitman - Plant Manager, Teys Bros Naracoorte

# 8 Abbreviations

Ecos	Ecos Consulting (Aust) Pty Ltd
EIR	Environmental Impact Report prepared in accordance with Section 97 of the <i>Petroleum Act 2000</i> and Regulation 10.
CEMP	Construction Environmental Management Plan
dB(A)	Decibels (A-weighted)
DEH	Department for Environment and Heritage
DAARE	Department of Aboriginal Affairs and Reconciliation
DWLBC	Department of Water, Land and Biodiversity Conservation
EMS	Environmental Management System
KP	Kilometre Point
PIRSA	Primary Industries and Resources, South Australia
SCADA	Supervisory Control and Data Acquisition
SEA Gas	South East Australia Gas Pty Ltd
SEO	Statement of Environmental Objectives prepared in accordance with Section 99 and 100 of the <i>Petroleum Act 2000</i> and Regulations 12 and 13.